

South Fork III Community Development District

Board of Supervisors

Scott Corder, Chairman
Darryl Dew, Vice Chairperson
Susan Peltz, Assistant Secretary
Vacant, Assistant Secretary
Vacant, Assistant Secretary

Mark Vega, District Manager
Kathryn "KC" Hopkinson, District Counsel
Tonja Stewart, District Engineer
Dustin Heflin, Field Manager

Continued Regular Meeting Agenda

Tuesday, March 28, 2023, at 5:00 p.m.

All cellular phones and pagers must be turned off during the meeting.

REGULAR MEETING OF BOARD OF SUPERVISORS

1. CALL TO ORDER/ROLL CALL

2. **PUBLIC COMMENT** Each individual has the opportunity to comment and is limited to **three (3) minutes** for such comment.

3. CONSENT AGENDA

- A. Acceptance of Board of Supervisor Resignation Tab 01
 - i. Jeffrey Hills
 - ii. Nicholas Dister
- B. Consideration of Board of Supervisor's Meeting Minutes of the Regular Meeting
February 14, 2023, Tab 02
- C. Consideration of Operation and Maintenance Expenditures January 2023 Tab 03
- D. Review of Financial Statements Month Ending January 31, 2023, Tab 04

4. STAFF REPORTS

- A. District Counsel
- B. District Engineer Tab 05
 - i. Permitted Drawings of Ambleside Blvd
- C. District Manager Tab 06
 - i. Ranking Sheets
 - ii. CDD Email System
- D. Onsite Manager

5. BOARD OF SUPERVISORS REQUESTS AND COMMENTS

6. ADJOURNMENT

We look forward to speaking with you at the meeting. In the meantime, if you have any questions, please do not hesitate to call us at (813) 873-7300.

Sincerely,

Mark Vega

District Manager

District Office

Inframark Community Development Services
2005 Pan Am Circle
Tampa, Florida 33607
(813) 873 - 7300

Meeting Location:

South Fork III Clubhouse
11771 Ambleside Blvd
Riverview, Florida 33579
(813) 608 - 8232

8 February 2023
Board of Supervisors – South Fork III CDD

Dear Board Members:

Please accept my letter of resignation as a member of the Board of Supervisors for the following Community Development District, effective immediately:

South Fork III CDD

Sincerely,

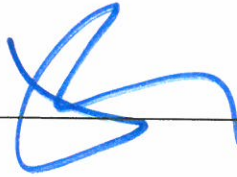
A handwritten signature in blue ink, consisting of several loops and a long horizontal stroke extending to the right.

Jeffery S. Hills

8 February 2023
Board of Supervisors – South Fork III CDD

Dear Board Members:

Please accept my letter of resignation as a member of the Board of Supervisors for the following Community Development District, effective immediately:

South Fork III CDD

Sincerely,

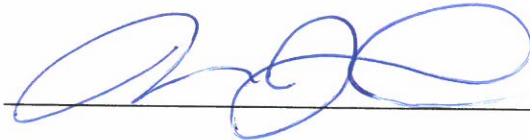
A handwritten signature in blue ink, consisting of several loops and a long horizontal stroke, positioned above a solid black horizontal line.

Nicholas J. Dister

**SOUTH FORK III
COMMUNITY DEVELOPMENT DISTRICT**

February 14, 2023, Minutes of the Regular Meeting

MINUTES OF THE REGULAR MEETING

The Regular Meeting of the Board of Supervisors of the South Fork III Community Development District was held on **Tuesday, February 14, 2023, at 5:00 p.m. at the South Fork III Clubhouse at 11771 Ambleside Blvd, Riverview, Florida 33579.**

1. CALL TO ORDER/ROLL CALL

Mark Vega called the Regular Meeting of the South Fork III Community Development District to order on **Tuesday, February 14, 2023, at 5:00 p.m.** and identified the Supervisors present constituting a quorum.

Supervisors Present and Constituting a Quorum at the onset of the meeting:

Darryl Dew	Vice Chairperson
Scott Corder	Supervisor
Susan Peltz	Supervisor

Staff Members Present

Mark Vega	District Manager, Inframark
Dustin Heflin	Field Manager

There were approximately nine audience members in attendance.

2. PUBLIC COMMENT ON AGENDA ITEMS

There were comments received from nine audience members present.

3. CONSENT AGENDA

- A. Discussion on HOA Special Event May 20, 2023, at the Pavilion**
- B. Consideration of Board of Supervisor’s Meeting Minutes of the Regular Meeting January 10, 2023**
- C. Consideration of Operation and Maintenance Expenditures December 2022**
- D. Review of Financial Statements Month Ending December 31, 2022,**

The Board reviewed and discussed the agenda items.

MOTION TO:	Approve the Consent Agenda items as described from A through D.
MADE BY:	Supervisor Corder
SECONDED BY:	Supervisor Dew
DISCUSSION:	None further
RESULT:	Called to Vote: Motion PASSED 3/0 - Motion Passed Unanimously

46 **4. STAFF REPORTS**

47 **A. District Counsel**

48
49 Mr. Vega announced Kathryn “KC” Hopkinson as the new District Counsel for South Fork III
50 CDD.

51
52 **B. District Manager**

53 **i. CDD Email System**

54
55 The Board tabled CDD email system until March after the Board reviews the first draft budget.

56
57 **ii. Discussion of Results of Landscape Proposals**

58
59 The Board will continue to discuss this item on March 23rd at 5:00 P.M.

60
61 **iii. Discussion of LMP Cost Savings Option**

62
63 A conversation ensued and the Board was in consensus to not cut services as recommended but
64 asked Mr Rinard to provide the fertilization dates of past installations.

65
66 **C. Onsite Manager**

67 **i. Surveillance Signage in Parking Lot**

68
69 The Board reviewed the surveillance signage in parking lot and by consensus, the Board authorize
70 Dustin to move forward with signs.

71
72 **D. District Engineer**

73
74 **5. BOARD OF SUPERVISORS REQUESTS AND COMMENTS**

75
76 There were no Board of Supervisors requests or comments currently.

77
78 **6. ADJOURNMENT**

79

80	MOTION TO:	Continue the meeting at 6:11 P.M. to March 23 rd of
81		2023 at 5:00 P.M. to discuss item 4. B-ii. Landscape
82		proposals.
83	MADE BY:	Supervisor Corder
84	SECONDED BY:	Supervisor Dew
85	DISCUSSION:	None Further
86	RESULT:	Called to Vote: Motion PASSED
87		3/0 - Motion Passed Unanimously

88
89

90 **Please note the entire meeting is available on disc.*

91

92 *These minutes were done in a summary format.

93
94 *Each person who decides to appeal any decision made by the Board with respect to any matter considered
95 at the meeting is advised that person may need to ensure that a verbatim record of the proceedings is made,
96 including the testimony and evidence upon which such appeal is to be based.

97 Meeting minutes were approved at a meeting by vote of the Board of Supervisors at a publicly noticed
98 meeting held on _____.

99
100 _____

101 **Signature**

_____ **Signature**

102
103 _____

104 **Printed Name**

_____ **Printed Name**

105
106 **Title:**

- 107 **Chair**
- 108 **Vice Chair**

106 **Title:**

- 107 **Secretary**
- 108 **Assistant Secretary**

109
110

Recorded by Records Administrator

111

Signature

112

113

Date

114
115
116
117

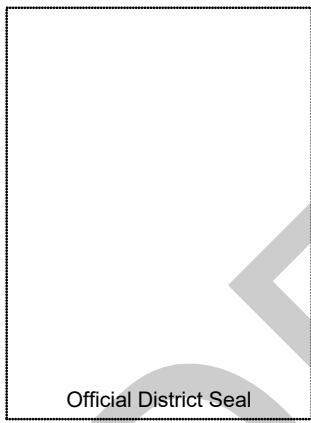

SOUTH FORK III CDD
Summary of Operations and Maintenance Invoices

Vendor	Invoice/Account Number	Amount	Vendor Total	Comments/Description
Monthly Contract				
FIRST CHOICE AQUATIC WEED MANAGEMENT LLC	79536	\$2,470.00		WATERWAY SERVICES JANUARY 2023
LANDSCAPE MAINTENANCE	173190	\$8,000.00		JANUARY 2023 MONTHLY LANDSCAPE MAINTENANCE
Monthly Contract Subtotal		\$10,470.00		
Variable Contract				
DARRYL F. DEW	DD 112922	\$200.00		SUPERVISOR FEE 11/29/22
Variable Contract Subtotal		\$200.00		
Utilities				
BOCC	2641583327 122722	\$55.50		WATER SERVICE 11/19/22-12/20/22
BOCC	7036042882 122722	\$109.31		WATER SERVICE 11/19/22-12/20/22
BOCC	8634535049 122722	\$365.51	\$530.32	WATER SERVICE 11/19/22-12/20/22
SPECTRUM	074519202012223	\$262.96		INTERNET SERVICES 01/21/23-02/20/23
SPECTRUM	096346401011123	\$89.97	\$352.93	INTERNET SERVICES 01/10/23-02/09/23
TAMPA ELECTRIC	211019161192 012323	\$316.77		ELECTRICITY SERVICES 12/15/22-01/17/23
TAMPA ELECTRIC	221000137812 012323	\$34.37		ELECTRICITY SERVICES 12/15/22-01/17/23
TAMPA ELECTRIC	221000137846 012323	\$33.68		ELECTRICITY SERVICES 12/15/22-01/17/23
TAMPA ELECTRIC	221002769828 012323	\$35.16		ELECTRICITY SERVICES 12/15/22-01/17/23
TAMPA ELECTRIC	221002798967 012323	\$842.41		ELECTRICITY SERVICES 12/15/22-01/17/23
TAMPA ELECTRIC	221007645890 012323	\$614.56		ELECTRICITY SERVICES 12/15/22-01/17/23
TAMPA ELECTRIC	221007876271 012323	\$519.44		ELECTRICITY SERVICES 12/15/22-01/17/23
TAMPA ELECTRIC	221007953351 012323	\$979.84		ELECTRICITY SERVICES 12/15/22-01/17/23
TAMPA ELECTRIC	221008035851 012323	\$2,659.57		ELECTRICITY SERVICES 12/15/22-01/17/23
TAMPA ELECTRIC	221008114474 012323	\$32.76		ELECTRICITY SERVICES 12/15/22-01/17/23
TAMPA ELECTRIC	221008114482 012323	\$34.15		ELECTRICITY SERVICES 12/15/22-01/17/23
TAMPA ELECTRIC	221008114490 012323	\$33.31		ELECTRICITY SERVICES 12/15/22-01/17/23
TAMPA ELECTRIC	221008126676 012323	\$31.31	\$6,167.33	ELECTRICITY SERVICES 12/15/22-01/17/23
Utilities Subtotal		\$7,050.58		
Regular Services				
LANDSCAPE MAINTENANCE	172728	\$6,615.00		DEAD TREE REMOVAL, CLEAN-UP, AND DISPOSAL
LANDSCAPE MAINTENANCE	172754	\$12,625.44		PLANT FILL IN AND REPLACEMENTS
LANDSCAPE MAINTENANCE	172856	\$128.83	\$19,369.27	IRRIGATION REPAIRS - 01/09/23
NEPTUNE SERVICES	0053267	\$425.00		BASKETBALL FENCE MAINT.
SOUTH FORK III CDD	01052023-1	\$30,124.50		SERIES 2019 V&W FY23 TAX DIST ID 606

SOUTH FORK III CDD Summary of Operations and Maintenance Invoices
--

Vendor	Invoice/Account Number	Amount	Vendor Total	Comments/Description
SOUTH FORK III CDD	01052023-2	\$2,481.36		SERIES 2018 FY23 TAX DIST ID 606
SOUTH FORK III CDD	01052023-3	\$16,709.71		SERIES 2016 FY23 TAX DIST ID 606
SOUTH FORK III CDD	12132022-26	\$4,537.30		SERIES 2016 FY23 TAX DIST ID 604
SOUTH FORK III CDD	12132022-27	\$673.78		SERIES 2018 FY23 TAX DIST ID 604
SOUTH FORK III CDD	12132022-28	\$8,179.90	\$62,706.55	SERIES 2019 V&W FY23 TAX DIST ID 604
STANTEC CONSULTING	2030134	\$244.00		PROJECT MANAGER SERVICES THRU - 12/30/22
TIMES PUBLISHING COM	84558-010423	\$520.50		RFP LANDSCAPE MAINT. SERVICES
Regular Services Subtotal		\$83,265.32		
Additional Services				
SOUTH FORK III COMMUNITY ASSOC	SFIII 011023	\$200,000.00		REPAYMENT OF LOAN FROM THE HOA TO THE CDD
Additional Services Subtotal		\$200,000.00		
TOTAL		\$300,985.90		

Approved (with any necessary revisions noted):

Signature:

Title (Check one):

Chariman Vice Chariman Assistant Secretary

Invoice

First Choice Aquatic Weed Management, LLC

P.O. Box 593258
Orlando, FL 32859

Phone: 407-859-2020
Fax: 407-859-3275

Date	Invoice #
1/17/2023	79536

Bill To
South Fork III CDD c/o Inframark 2005 Pan Am Circle Dr., Ste. 300 Tampa, FL 33607

Customer P.O. No.	Payment Terms	Due Date
	Net 30	2/16/2023

Description	Amount
Monthly waterway service for the month this invoice is dated - 27 waterways and 1 swale. Light Debris pickup included	2,470.00

Thank you for your business.

Total	\$2,470.00
Payments/Credits	\$0.00
Balance Due	\$2,470.00



Corporate Office
 PO Box 267
 Seffner, FL 33583

813-757-6500
813-757-6501

Invoice

Date	Invoice #
2/1/2023	173190

Bill To:
South Fork III CDD c/o Inframark 210 N University Dr #702 Coral Springs, FL 33071

Property Information

Services for the month January 2023

Description	Qty	Rate	Amount
Monthly Ground Maintenance	1	8,000.00	8,000.00

			Total	\$8,000.00
Questions regarding this invoice? Please e-mail arpayments@lmppro.com or call 813-757-6500 and ask for Accounts Receivable.	Terms	Due Date	Payments/Credits	\$0.00
	Net 30	3/3/2023	Balance Due	\$8,000.00

SOUTH FORK III CDD

MEETING DATE November 29, 2022

DMS Staff Signature: Per Mark Vega

SUPERVISORS	CHECK IF IN ATTENDANCE	STATUS	PAYMENT AMOUNT
Jeff Hills		Salary Accepted	\$200.00
Nicholas Dister		Salary Accepted	\$200.00
Susan Petlz	X	Salary Accepted	\$200.00
Scott Corder	X	Salary Accepted	\$200.00
Darryl Dew	X	Salary Accepted	\$200.00

DD 112922



Hillsborough County Florida

CUSTOMER NAME SOUTH FORK III CDD	ACCOUNT NUMBER 2641583327	BILL DATE 12/27/2022	DUE DATE 01/17/2023
--	-------------------------------------	--------------------------------	-------------------------------



Service Address: 13600 ASHLAR SLATE PL (IRRIGATION METER)

S-Page 1 of 1

METER NUMBER	PREVIOUS DATE	PREVIOUS READ	PRESENT DATE	PRESENT READ	CONSUMPTION	READ TYPE	METER DESCRIPTION
38350841	11/19/2022	12355	12/20/2022	12380	2500 GAL	ACTUAL	WATER

Service Address Charges

Customer Service Charge	\$5.28
Purchase Water Pass-Thru	\$7.55
Water Base Charge	\$16.03
Water Usage Charge	\$2.25

Miscellaneous Charges

Late Payment Charge	\$2.18
Total Miscellaneous Charges	\$2.18

Summary of Account Charges

Previous Balance	\$43.52
Net Payments - Thank You	\$-21.31
Past Due Amount	\$22.21
Bill Adjustments	\$2.18
Total Account Charges	\$31.11

AMOUNT DUE	\$55.50
-------------------	----------------

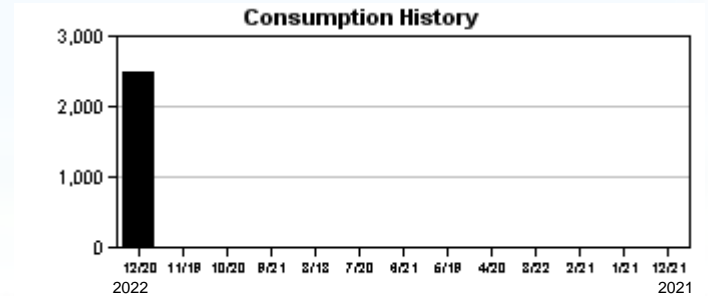

Hillsborough County Florida

Make checks payable to: **BOCC**

ACCOUNT NUMBER: 2641583327



ELECTRONIC PAYMENTS BY CHECK OR

Automated Payment Line: (813) 276 8526
 Internet Payments: HCFLGov.net/WaterBill
 Additional Information: HCFLGov.net/Water



**** NOTICE ** THE BALANCE REFLECTS A PAST DUE AMOUNT TO AVOID DISCONNECTION OF SERVICE, PAYMENT MUST BE RECEIVED BY 3:00 P.M. ON THE DUE DATE**



SOUTH FORK III CDD
 2005 PAN AM CIR STE 300
 TAMPA FL 33607-6008

1,760 8

DUE DATE	01/17/2023
AMOUNT DUE	\$55.50
AMOUNT PAID	

0026415833271 00000055509



Hillsborough County Florida

CUSTOMER NAME SOUTH FORK III CDD	ACCOUNT NUMBER 7036042882	BILL DATE 12/27/2022	DUE DATE 01/17/2023
--	-------------------------------------	--------------------------------	-------------------------------



Service Address: 11601 PRADERA RESERVE BLVD

S-Page 1 of 1

METER NUMBER	PREVIOUS DATE	PREVIOUS READ	PRESENT DATE	PRESENT READ	CONSUMPTION	READ TYPE	METER DESCRIPTION
61120617	11/19/2022	1147	12/20/2022	1183	3600 GAL	ACTUAL	WATER

Service Address Charges

Customer Service Charge	\$5.28
Purchase Water Pass-Thru	\$10.87
Water Base Charge	\$18.34
Water Usage Charge	\$3.24
Sewer Base Charge	\$44.35
Sewer Usage Charge	\$20.56

Summary of Account Charges

Previous Balance	\$133.46
Net Payments - Thank You	\$-133.46
Bill Adjustments	\$6.67
Total Account Charges	\$102.64

AMOUNT DUE	\$109.31
-------------------	-----------------

Miscellaneous Charges

Late Payment Charge	\$6.67
Total Miscellaneous Charges	\$6.67

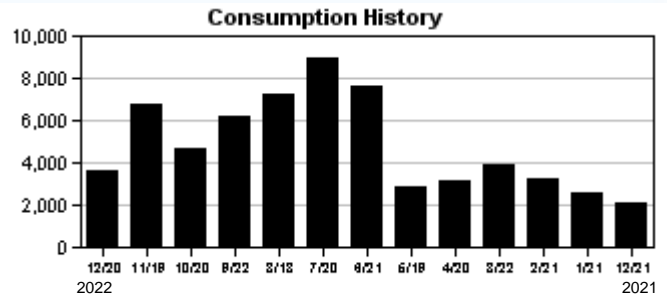

Hillsborough County Florida

Make checks payable to: **BOCC**

ACCOUNT NUMBER: 7036042882



ELECTRONIC PAYMENTS BY CHECK OR

Automated Payment Line: (813) 276 8526
 Internet Payments: HCFLGov.net/WaterBill
 Additional Information: HCFLGov.net/Water



THANK YOU!



SOUTH FORK III CDD
 2005 PAN AM CIR STE 300
 TAMPA FL 33607-6008

2,058 8

DUE DATE	01/17/2023
AMOUNT DUE	\$109.31
AMOUNT PAID	

13
 0070360428828 00000109314



Hillsborough County Florida

CUSTOMER NAME SOUTH FORK III CDD	ACCOUNT NUMBER 8634535049	BILL DATE 12/27/2022	DUE DATE 01/17/2023
--	-------------------------------------	--------------------------------	-------------------------------



Service Address: 11771 AMBLESIDE BLVD

S-Page 1 of 1

METER NUMBER	PREVIOUS DATE	PREVIOUS READ	PRESENT DATE	PRESENT READ	CONSUMPTION	READ TYPE	METER DESCRIPTION
60994081	11/19/2022	10544	12/20/2022	10606	6200 GAL	ACTUAL	WATER

Service Address Charges

Customer Service Charge	\$5.28
Purchase Water Pass-Thru	\$18.72
Water Base Charge	\$57.54
Water Usage Charge	\$5.58
Sewer Base Charge	\$242.68
Sewer Usage Charge	\$35.40

Summary of Account Charges

Previous Balance	\$6.20
Net Payments - Thank You	\$-6.20
Bill Adjustments	\$0.31
Total Account Charges	\$365.20

AMOUNT DUE	\$365.51
-------------------	-----------------

Miscellaneous Charges

Late Payment Charge	\$0.31
Total Miscellaneous Charges	\$0.31

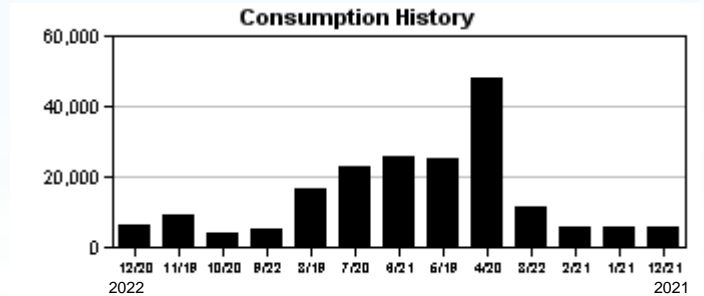

Hillsborough County Florida

Make checks payable to: **BOCC**

ACCOUNT NUMBER: 8634535049



ELECTRONIC PAYMENTS BY CHECK OR

Automated Payment Line: (813) 276 8526
 Internet Payments: HCFLGov.net/WaterBill
 Additional Information: HCFLGov.net/Water

THANK YOU!



SOUTH FORK III CDD
2005 PAN AM CIR STE 300
TAMPA FL 33607-6008

562 8

DUE DATE	01/17/2023
AMOUNT DUE	\$365.51
AMOUNT PAID	

0086345350499 00000365510

Received

JAN 27 2023

January 22, 2023
 Invoice Number: 074519202012223
 Account Number: 0050745192-02
 Security Code: 3034
 Service At: 11771 AMBLESIDE BLVD
 RIVERVIEW, FL 33579

NEWS AND INFORMATION

Contact Us
 Visit us at SpectrumBusiness.net
 Or, call us at 1-877-824-6249

NOTE. Taxes, Fees and Charges listed in the Summary only apply to Spectrum Business TV and Spectrum Business Internet and are detailed on the following page.

Choose the mobile package that fits your business needs with Spectrum Business. Call 1-833-954-3509 today!



Summary *Services from 01/21/23 through 02/20/23 details on following pages*

Previous Balance	242.96
Payments Received - Thank You	-242.96
Remaining Balance	\$0.00
Spectrum Business™ Internet	227.97
Spectrum Business™ Voice	34.99
Current Charges	\$262.96
Total Due by 02/07/23	\$262.96

Thank you for choosing Spectrum Business.
 We appreciate your prompt payment and value you as a customer.



4145 S. Falkenburg Rd Riverview, FL 33578-8652
 7635 1610 NO RP 22 01222023 NNNNNY 01 000217 0001

SOUTH FORK III CCD
 2005 PAN AM CIR
 STE 300
 TAMPA FL 33607-6008



January 22, 2023
SOUTH FORK III CCD

Invoice Number: 074519202012223
 Account Number: 0050745192-02
 Service At: 11771 AMBLESIDE BLVD
 RIVERVIEW, FL 33579

Total Due by 02/07/23	\$262.96
Amount you are enclosing	\$

Please Remit Payment To:
 CHARTER COMMUNICATIONS
 PO BOX 7195
 PASADENA, CA 91109-7195



Invoice Number: 074519202012223
 Account Number: 0050745192-02
 Security Code: 3034

Contact Us
 Visit us at SpectrumBusiness.net
 Or, call us at 1-877-824-6249
 7635 1610 NO RP 22 01222023 NNNNNY 01 000217 0001

Charge Details

Previous Balance	242.96
Payments Received - Thank You 01/20	-242.96
Remaining Balance	\$0.00

Payments received after 01/22/23 will appear on your next bill.

Services from 01/21/23 through 02/20/23

Spectrum Business™ Internet

Spectrum Business Internet Ultra	199.99
Static IP 1	19.99
Business WiFi	7.99
	\$227.97

Spectrum Business™ Internet Total **\$227.97**

Spectrum Business™ Voice

Phone Number 813-442-5461

Directory Listing	0.00
Spectrum Business Voice	49.99
Promotional Discount	-15.00
	\$34.99

For additional call details, please visit SpectrumBusiness.net Taxes, Fees and Charges for Spectrum Business Voice are detailed in the Billing Information section.

Spectrum Business™ Voice Total **\$34.99**

Current Charges	\$262.96
Total Due by 02/07/23	\$262.96

Billing Information

Terms & Conditions - Spectrum's detailed standard terms and conditions for service are located at spectrum.com/policies.

Visit Spectrum.com/stores for store locations. For questions or concerns, visit Spectrum.net/support.

Sign up for Paperless Billing.
 It's easy, convenient and secure.

Get your statement as soon as it's available. Instead of receiving a paper bill through the mail, sign up for paperless billing.

- It's easy** – enroll in paperless billing visit SpectrumBusiness.net.
- It's convenient** – you can access your statement through SpectrumBusiness.net.
- It's secure** – we deliver securely to your SpectrumBusiness.net account and only you can access through a secure sign-in process.

Each month, you'll receive a paperless e-bill that you pay online with your choice of payment options.



Tax and Fees - This statement reflects the current taxes and fees for your area (including sales, excise, user taxes, etc.). These taxes and fees may change without notice. Visit spectrum.net/taxesandfees for more information.

Spectrum Terms and Conditions of Service – In accordance with the Spectrum Business Services Agreement, Spectrum services are billed on a monthly basis. Spectrum does not provide credits for monthly subscription services that are cancelled prior to the end of the current billing month.

Past Due Fee / Late Fee Reminder - A late fee will be assessed for past due charges for service.

The following taxes, fees and surcharges are included in the price of the applicable service - Federal USF \$2.04, Florida State CST \$1.53, Florida Local CST \$1.50, Florida CST \$0.79, E911 Fee \$0.40, TRS Surcharge \$0.10, Sales Tax \$0.03.

Billing Practices - Spectrum Business mails monthly, itemized invoices for all monthly services in advance. A full payment is required on or before the due date indicated on this invoice. Payments made after the indicated due date may result in a late payment processing charge. Failure to pay could result in the disconnection of all your Spectrum Business service(s). Disconnection of Business Voice service may also result in the loss of your phone number.

Changing Business Locations - Please contact Spectrum Business before moving your Business Voice modem to a new address. To establish service at your new location or return equipment, please contact your Spectrum Business Account Executive at least twenty one (21) business days prior to your move.

Authorization to Convert your Check to an Electronic Funds Transfer Debit - For your convenience, if you provide a check as payment, you authorize Spectrum Business to use the information from your check to make a one-time electronic funds transfer from your account. If you have any questions, please call our office at the telephone number on the front of this invoice. To assist you in future payments, your bank or credit card account information may be electronically stored in our system in a secure, encrypted manner.

Complaint Procedures - If you disagree with your charges, you need to register a complaint no later than 60 days after the due date on your bill statement.

Payment Options

Pay Online - Create or Login to pay or view your bill online at Spectrumbusiness.net.

Pay by Mail - Detach payment coupon and enclose with your check made payable to Bright House Networks. Please do not include correspondences of any type with payments.

For questions or concerns, please call **1-877-824-6249**.



Received

JAN 19 2023

January 11, 2023
 Invoice Number: 096346401011123
 Account Number: 0050963464-01
 Security Code: 7807
 Service At: 11601 PRADERA RESERVE BLVD
 RIVERVIEW, FL 33579-0000

NEWS AND INFORMATION

Contact Us
 Visit us at SpectrumBusiness.net
 Or, call us at 1-877-824-6249

NOTE. Taxes, Fees and Charges listed in the Summary only apply to Spectrum Business TV and Spectrum Business Internet and are detailed on the following page.

IMPORTANT BILLING UPDATE. At Spectrum Business, we work hard on your behalf to keep prices as low as possible. We value your business and are committed to providing you with the latest products and technology. Effective with this statement, we are making a price correction. As a result, Spectrum Business Voice will increase by \$5/mo.



Important Billing Update: In order to continue to provide you with the best customer service, we are upgrading our billing system on or after February 8, 2023. You will receive a new account number and your payments will need to be sent to a new remittance address after February 8, 2023. **Your new account number and new remittance address will be provided to you on your next statement. No changes are required until you receive the statement with the new account number and new remittance address.**

Choose a sports and entertainment package that fits your needs with Spectrum Business TV. Call 1-855-759-3880 today!

Choose the mobile package that fits your business needs with Spectrum Business. Call 1-855-251-3927 today!

Summary *Services from 01/10/23 through 02/09/23 details on following pages*

Previous Balance	94.97
Payments Received - Thank You	-94.97
Remaining Balance	\$0.00
Spectrum Business™ Internet	69.98
Spectrum Business™ Voice	19.99
Current Charges	\$89.97
Total Due by 01/27/23	\$89.97

Thank you for choosing Spectrum Business.
 We appreciate your prompt payment and value you as a customer.



January 11, 2023

SFORK 3 CDD

Invoice Number: 096346401011123
 Account Number: 0050963464-01
 Service At: 11601 PRADERA RESERVE BLVD
 RIVERVIEW, FL 33579-0000

Total Due by 01/27/23	\$89.97
Amount you are enclosing	\$

Please Remit Payment To:

CHARTER COMMUNICATIONS
 PO BOX 7195
 PASADENA, CA 91109-7195



Invoice Number: 09634640101123
 Account Number: 0050963464-01
 Security Code: 7807

SFORK 3 CDD
 09634640101123
 0050963464-01
 7807

Contact Us

Visit us at SpectrumBusiness.net
 Or, call us at 1-877-824-6249

7635 1610 NO RP 11 01112023 NNNNNY 01 001493 0006

Charge Details

Previous Balance		94.97
Payments Received - Thank You	01/04	-94.97
Remaining Balance		\$0.00

Payments received after 01/11/23 will appear on your next bill.

Services from 01/10/23 through 02/09/23

Spectrum Business™ Internet

Spectrum Business Internet Ultra	199.99
Static IP 1	19.99
Promotional Discount	-90.00
Bundle Discount	-60.00
	\$69.98

Spectrum Business™ Internet Total **\$69.98**

Spectrum Business™ Voice

Phone Number 813-443-6062	
Spectrum Business Voice	49.99
Promotional Discount	-20.00
Promo Discount	-10.00
	\$19.99

For additional call details, please visit SpectrumBusiness.net Taxes, Fees and Charges for Spectrum Business Voice are detailed in the Billing Information section.

Spectrum Business™ Voice Total **\$19.99**

Current Charges **\$89.97**
Total Due by 01/27/23 **\$89.97**

Billing Information

Spectrum Voice Provider - Spectrum Advanced Services, LLC

Visit Spectrum.com/stores for store locations. For questions or concerns, visit Spectrum.net/support.

Simplify your life with Auto Pay!

Spend less time paying your bill
 and more time doing what you love.

It's Easy - No more checks, stamps or trips to the post office
 It's Secure - Powerful technology keeps your information safe
 It's Flexible - Use your checking, savings, debit or credit card
 It's **FREE** - And helps save time, postage and the environment

Set up easy, automatic bill payments with **Auto Pay!**

Visit: Spectrumbusiness.net
 (My Services login required)



Tax and Fees - This statement reflects the current taxes and fees for your area (including sales, excise, user taxes, etc.). These taxes and fees may change without notice. Visit spectrum.net/taxesandfees for more information.

Spectrum Terms and Conditions of Service - In accordance with the Spectrum Business Services Agreement, Spectrum services are billed on a monthly basis. Spectrum does not provide credits for monthly subscription services that are cancelled prior to the end of the current billing month.

Terms & Conditions - Spectrum's detailed standard terms and conditions for service are located at spectrum.com/policies.

Past Due Fee / Late Fee Reminder - A late fee will be assessed for past due charges for service.

The following taxes, fees and surcharges are included in the price of the applicable service - Federal USF \$1.23, Florida State CST \$0.93, Florida Local CST \$0.91, Florida CST \$0.48, E911 Fee \$0.40, TRS Surcharge \$0.10, Sales Tax \$0.02.

Billing Practices - Spectrum Business mails monthly, itemized invoices for all monthly services in advance. A full payment is required on or before the due date indicated on this invoice. Payments made after the indicated due date may result in a late payment processing charge. Failure to pay could result in the disconnection of all your Spectrum Business service(s). Disconnection of Business Voice service may also result in the loss of your phone number.

Changing Business Locations - Please contact Spectrum Business before moving your Business Voice modem to a new address. To establish service at your new location or return equipment, please contact your Spectrum Business Account Executive at least twenty one (21) business days prior to your move.

Authorization to Convert your Check to an Electronic Funds Transfer Debit - For your convenience, if you provide a check as payment, you authorize Spectrum Business to use the information from your check to make a one-time electronic funds transfer from your account. If you have any questions, please call our office at the telephone number on the front of this invoice. To assist you in future payments, your bank or credit card account information may be electronically stored in our system in a secure, encrypted manner.

Payment Options

Pay Online - Create or Login to pay or view your bill online at Spectrumbusiness.net.

Pay by Mail - Detach payment coupon and enclose with your check made payable to Bright House Networks. Please do not include correspondences of any type with payments.

For questions or concerns, please call **1-877-824-6249**.



Received

JAN 27 2023

ACCOUNT INVOICE

tampaelectric.com



Statement Date: 01/23/2023
Account: 211019161192

SOUTH FORK III COMMUNITY
11615 PRADERA RESERVE BLVD
RIVERVIEW, FL 33579



Current month's charges:	\$323.45
Total amount due:	\$316.77
Payment Due By:	02/13/2023

Your Account Summary

Previous Amount Due	\$113.39
Payment(s) Received Since Last Statement	-\$113.39
Miscellaneous Credits	-\$6.68
Credit balance after payments and credits	-\$6.68
Current Month's Charges	\$323.45
Total Amount Due	\$316.77

0000025-0000558-Page 55 of 58

**Save Energy.
Save Money.**

It's never been easier with help from our many rebate programs for business.

tampaelectric.com/bizsave

Amount not paid by due date may be assessed a late payment charge and an additional deposit.

SCAM ALERT!

Scammers are calling. Don't be a victim.

- Scammers can alter caller ID numbers to make it look like TECO is calling.
- We will never ask you to purchase a prepaid card or download a payment app.
- **Know what you owe.** Reference your most recent bill or log in to your online account.
- If you think a call is a scam, hang up.

To learn more, or to report a scam, visit tampaelectric.com/scam

To ensure prompt credit, please return stub portion of this bill with your payment. Make checks payable to TECO.



WAYS TO PAY YOUR BILL



See reverse side for more information

Account: 211019161192

Current month's charges:	\$323.45
Total amount due:	\$316.77
Payment Due By:	02/13/2023
Amount Enclosed	\$ _____

639038231950

SOUTH FORK III COMMUNITY
2005 PAN AM CIR, STE 300
TAMPA, FL 33607-6008

MAIL PAYMENT TO:
TECO
P.O. BOX 31318
TAMPA, FL 33631-3318

6390382319502110191611920000000316779

Account: 211019161192
Statement Date: 01/23/2023
Current month's charges due 02/13/2023



Details of Charges – Service from 12/15/2022 to 01/17/2023

Service for: 11615 PRADERA RESERVE BLVD, RIVERVIEW, FL 33579

Rate Schedule: General Service - Non Demand

Meter Location: WELL

0000025-0000560-Page 37 of 58

Meter Number	Read Date	Current Reading	-	Previous Reading	=	Total Used	Multiplier	Billing Period
1000864583	01/17/2023	18,947		16,859		2,088 kWh	1	34 Days

Daily Basic Service Charge	34 days @ \$0.75000	\$25.50
Energy Charge	2,088 kWh @ \$0.07990/kWh	\$166.83
Fuel Charge	2,088 kWh @ \$0.04832/kWh	\$100.89
Storm Protection Charge	2,088 kWh @ \$0.00400/kWh	\$8.35
Clean Energy Transition Mechanism	2,088 kWh @ \$0.00427/kWh	\$8.92
Florida Gross Receipt Tax		\$7.96
Electric Service Cost		\$318.45
Other Fees and Charges		
Electric Late Payment Fee		\$5.00
Total Other Fees and Charges		\$5.00
Total Current Month's Charges		\$323.45

Tampa Electric Usage History

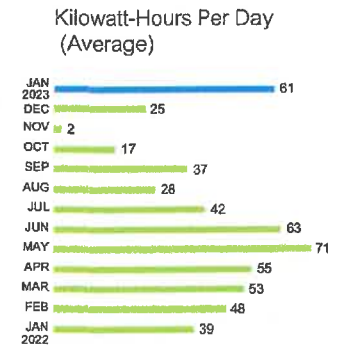

Miscellaneous Credits

Interest for Cash Security Deposit - Electric	-\$6.68
Total Current Month's Credits	-\$6.68

Important Messages

Annual Deposit Interest Credit

This billing statement reflects your annual credit of deposit interest. Thank you for being a valued customer. We appreciate the opportunity to serve you.

Statement Date: 01/23/2023
Account: 221000137812

SOUTH FORK III COMMUNITY
11770 AMBLESIDE BLVD
RIVERVIEW, FL 33578



Current month's charges:	\$34.37
Total amount due:	\$34.37
Payment Due By:	02/13/2023

Your Account Summary

Previous Amount Due	\$30.65
Payment(s) Received Since Last Statement	-\$30.65
Current Month's Charges	\$34.37
Total Amount Due	\$34.37

0000025-0000538-Page 15 of 58

**Save Energy.
Save Money.**

It's never been easier with help from our many rebate programs for business.

tampaelectric.com/bizsave

Amount not paid by due date may be assessed a late payment charge and an additional deposit.

SCAM ALERT!

Scammers are calling. Don't be a victim.

- Scammers can alter caller ID numbers to make it look like TECO is calling.
- We will never ask you to purchase a prepaid card or download a payment app.
- **Know what you owe.** Reference your most recent bill or log in to your online account.
- If you think a call is a scam, hang up.

To learn more, or to report a scam, visit tampaelectric.com/scam

To ensure prompt credit, please return stub portion of this bill with your payment. Make checks payable to TECO.



WAYS TO PAY YOUR BILL



See reverse side for more information

Account: 221000137812

Current month's charges:	\$34.37
Total amount due:	\$34.37
Payment Due By:	02/13/2023
Amount Enclosed	\$ _____

692124412472

SOUTH FORK III COMMUNITY
2005 PAN AM CIR, STE 300
TAMPA, FL 33607-6008

MAIL PAYMENT TO:
TECO
P.O. BOX 31318
TAMPA, FL 33631-3318

Account: 221000137812
Statement Date: 01/23/2023
Current month's charges due 02/13/2023



Details of Charges – Service from 12/15/2022 to 01/17/2023

Service for: 11770 AMBLESIDE BLVD, RIVERVIEW, FL 33578

Rate Schedule: General Service - Non Demand

Meter Number	Read Date	Current Reading	-	Previous Reading	=	Total Used	Multiplier	Billing Period
1000555994	01/17/2023	718		695		23 kWh	1	34 Days

0000025-0000540-Page 17 of 58

Daily Basic Service Charge	34 days @ \$0.75000	\$25.50	
Energy Charge	23 kWh @ \$0.07990/kWh	\$1.84	
Fuel Charge	23 kWh @ \$0.04832/kWh	\$1.11	
Storm Protection Charge	23 kWh @ \$0.00400/kWh	\$0.09	
Clean Energy Transition Mechanism	23 kWh @ \$0.00427/kWh	\$0.10	
Florida Gross Receipt Tax		\$0.73	
Electric Service Cost			\$29.37
Other Fees and Charges			
Electric Late Payment Fee		\$5.00	
Total Other Fees and Charges			\$5.00
Total Current Month's Charges			\$34.37

Tampa Electric Usage History

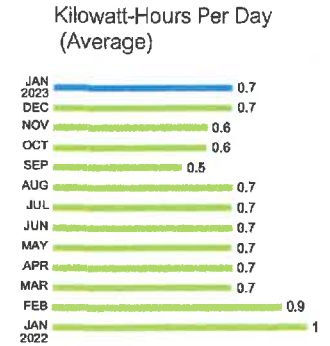

Received
JAN 27 2023
7 2023

tampaelectric.com



Statement Date: 01/23/2023
Account: 221000137846

SOUTH FORK III COMMUNITY
11685 AMBLESIDE BLVD
RIVERVIEW, FL 33578



Current month's charges:	\$34.94
Total amount due:	\$33.68
Payment Due By:	02/13/2023

Your Account Summary

Previous Amount Due	\$24.79
Payment(s) Received Since Last Statement	-\$24.79
Miscellaneous Credits	-\$1.26
Credit balance after payments and credits	-\$1.26
Current Month's Charges	\$34.94
Total Amount Due	\$33.68

**Save Energy.
Save Money.**

It's never been easier with help from our many rebate programs for business.

tampaelectric.com/bizsave

0000025-0000335-Page 7 of 58

Amount not paid by due date may be assessed a late payment charge and an additional deposit.

SCAM ALERT!

Scammers are calling. Don't be a victim.

- Scammers can alter caller ID numbers to make it look like TECO is calling.
- We will never ask you to purchase a prepaid card or download a payment app.
- **Know what you owe.** Reference your most recent bill or log in to your online account.
- If you think a call is a scam, hang up.

To learn more, or to report a scam, visit tampaelectric.com/scam

To ensure prompt credit, please return stub portion of this bill with your payment. Make checks payable to TECO.



WAYS TO PAY YOUR BILL



See reverse side for more information

Account: 221000137846

Current month's charges:	\$34.94
Total amount due:	\$33.68
Payment Due By:	02/13/2023
Amount Enclosed	\$

692124412473

SOUTH FORK III COMMUNITY
2005 PAN AM CIR, STE 300
TAMPA, FL 33607-6008

MAIL PAYMENT TO:
TECO
P.O. BOX 31318
TAMPA, FL 33631-3318

Account: 221000137846
Statement Date: 01/23/2023
Current month's charges due 02/13/2023



Details of Charges – Service from 12/15/2022 to 01/17/2023

Service for: 11685 AMBLESIDE BLVD, RIVERVIEW, FL 33578

Rate Schedule: General Service - Non Demand

Meter Number	Read Date	Current Reading	-	Previous Reading	=	Total Used	Multiplier	Billing Period
1000832120	01/17/2023	403		376		27 kWh	1	34 Days

0000025-000536-Page 9 of 99

Daily Basic Service Charge	34 days @ \$0.75000	\$25.50
Energy Charge	27 kWh @ \$0.07990/kWh	\$2.16
Fuel Charge	27 kWh @ \$0.04832/kWh	\$1.30
Storm Protection Charge	27 kWh @ \$0.00400/kWh	\$0.11
Clean Energy Transition Mechanism	27 kWh @ \$0.00427/kWh	\$0.12
Florida Gross Receipt Tax		\$0.75
Electric Service Cost		\$29.94
Other Fees and Charges		
Electric Late Payment Fee		\$5.00
Total Other Fees and Charges		\$5.00
Total Current Month's Charges		\$34.94

Tampa Electric Usage History

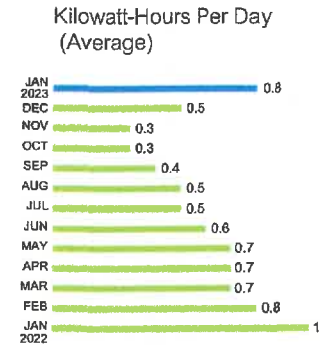

Miscellaneous Credits

Interest for Cash Security Deposit - Electric	-\$1.26
Total Current Month's Credits	-\$1.26

Important Messages

Annual Deposit Interest Credit

This billing statement reflects your annual credit of deposit interest. Thank you for being a valued customer. We appreciate the opportunity to serve you.

Received
JAN 27 2023

tampaelectric.com



Statement Date: 01/23/2023
Account: 221002769828

SOUTH FORK III COMMUNITY
11774 AMBLESIDE BLVD
RIVERVIEW, FL 33579



Current month's charges:	\$36.48
Total amount due:	\$35.16
Payment Due By:	02/13/2023

Your Account Summary

Previous Amount Due	\$28.09
Payment(s) Received Since Last Statement	-\$28.09
Miscellaneous Credits	-\$1.32
Credit balance after payments and credits	-\$1.32
Current Month's Charges	\$36.48
Total Amount Due	\$35.16

0000025-0000533-Page 3 of 58

**Save Energy.
Save Money.**

It's never been easier with help from our many rebate programs for business.

tampaelectric.com/bizsave

Amount not paid by due date may be assessed a late payment charge and an additional deposit.

SCAM ALERT!

Scammers are calling. Don't be a victim.

- Scammers can alter caller ID numbers to make it look like TECO is calling.
- We will never ask you to purchase a prepaid card or download a payment app.
- **Know what you owe.** Reference your most recent bill or log in to your online account.
- If you think a call is a scam, hang up.

To learn more, or to report a scam, visit tampaelectric.com/scam

To ensure prompt credit, please return stub portion of this bill with your payment. Make checks payable to TECO.



WAYS TO PAY YOUR BILL



See reverse side for more information

Account: 221002769828

Current month's charges:	\$36.48
Total amount due:	\$35.16
Payment Due By:	02/13/2023
Amount Enclosed	\$ _____

636569091541

SOUTH FORK III COMMUNITY
2005 PAN AM CIR, STE 300
TAMPA, FL 33607-6008

MAIL PAYMENT TO:
TECO
P.O. BOX 31318
TAMPA, FL 33631-3318

Account: 221002769828
Statement Date: 01/23/2023
Current month's charges due 02/13/2023



Details of Charges – Service from 12/15/2022 to 01/17/2023

Service for: 11774 AMBLESIDE BLVD, RIVERVIEW, FL 33579

Rate Schedule: General Service - Non Demand

Meter Location: ENTRANCE

00000025-0000534-Page 5 of 58

Meter Number	Read Date	Current Reading	Previous Reading	Total Used	Multiplier	Billing Period
1000555995	01/17/2023	1,351	1,313	38 kWh	1	34 Days

Daily Basic Service Charge	34 days @ \$0.75000	\$25.50	
Energy Charge	38 kWh @ \$0.07990/kWh	\$3.04	
Fuel Charge	38 kWh @ \$0.04832/kWh	\$1.84	
Storm Protection Charge	38 kWh @ \$0.00400/kWh	\$0.15	
Clean Energy Transition Mechanism	38 kWh @ \$0.00427/kWh	\$0.16	
Florida Gross Receipt Tax		\$0.79	
Electric Service Cost			\$31.48
Other Fees and Charges			
Electric Late Payment Fee		\$5.00	
Total Other Fees and Charges			\$5.00
Total Current Month's Charges			\$36.48

Tampa Electric Usage History

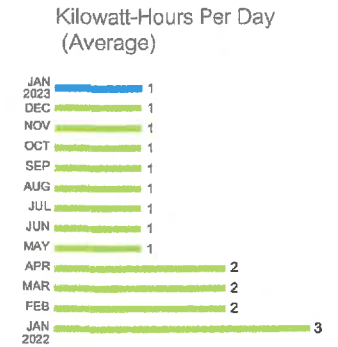

Miscellaneous Credits

Interest for Cash Security Deposit - Electric	-\$1.32
Total Current Month's Credits	-\$1.32

Important Messages

Annual Deposit Interest Credit

This billing statement reflects your annual credit of deposit interest. Thank you for being a valued customer. We appreciate the opportunity to serve you.

Received

JAN 27 2023

tampaelectric.com



Statement Date: 01/23/2023

Account: 221002798967

SOUTH FORK III COMMUNITY
11771 AMBLESIDE BL
RIVERVIEW, FL 33579



Current month's charges:	\$870.49
Total amount due:	\$842.41
Payment Due By:	02/13/2023

Your Account Summary

Previous Amount Due	\$654.88
Payment(s) Received Since Last Statement	-\$654.88
Miscellaneous Credits	-\$28.08
Credit balance after payments and credits	-\$28.08
Current Month's Charges	\$870.49
Total Amount Due	\$842.41

0000025-0000537-Page 11 of 58

**Save Energy.
Save Money.**

It's never been easier with help from our many rebate programs for business.

tampaelectric.com/bizsave

Amount not paid by due date may be assessed a late payment charge and an additional deposit.

SCAM ALERT!

Scammers are calling. Don't be a victim.

- Scammers can alter caller ID numbers to make it look like TECO is calling.
- We will never ask you to purchase a prepaid card or download a payment app.
- **Know what you owe.** Reference your most recent bill or log in to your online account.
- If you think a call is a scam, hang up.

To learn more, or to report a scam, visit tampaelectric.com/scam

To ensure prompt credit, please return stub portion of this bill with your payment. Make checks payable to TECO.



See reverse side for more information

Account: 221002798967

Current month's charges:	\$870.49
Total amount due:	\$842.41
Payment Due By:	02/13/2023

Amount Enclosed \$ _____
636569091542

SOUTH FORK III COMMUNITY
2005 PAN AM CIR, STE 300
TAMPA, FL 33607-6008

MAIL PAYMENT TO:
TECO
P.O. BOX 31318
TAMPA, FL 33631-3318

Account: 221002798967
Statement Date: 01/23/2023
Current month's charges due 02/13/2023



Details of Charges – Service from 12/15/2022 to 01/17/2023

Service for: 11771 AMBLESIDE BL, RIVERVIEW, FL 33579

Rate Schedule: General Service Demand - Standard

Meter Number	Read Date	Current Reading	Previous Reading	=	Total Used	Multiplier	Billing Period
1000345731	01/17/2023	74,473	65,879		8,594 kWh	1	34 Days
1000345731	01/17/2023	19.29	0		19.29 kW	1	34 Days

0000025-0000538-Page 13 of 58

Daily Basic Service Charge	34 days @ \$1.08000	\$36.72
Billing Demand Charge	19 kW @ \$14.13000/kW	\$268.47
Energy Charge	8,594 kWh @ \$0.00736/kWh	\$63.25
Fuel Charge	8,594 kWh @ \$0.04832/kWh	\$415.26
Capacity Charge	19 kW @ -\$0.06000/kW	-\$1.14
Storm Protection Charge	19 kW @ \$0.62000/kW	\$11.78
Energy Conservation Charge	19 kW @ \$0.88000/kW	\$16.72
Environmental Cost Recovery	8,594 kWh @ \$0.00084/kWh	\$7.22
Clean Energy Transition Mechanism	19 kW @ \$1.12000/kW	\$21.28
Florida Gross Receipt Tax		\$21.53

Electric Service Cost

\$861.09

Other Fees and Charges

Electric Late Payment Fee \$9.40

Total Other Fees and Charges

\$9.40

Total Current Month's Charges

\$870.49

Miscellaneous Credits

Interest for Cash Security Deposit - Electric -\$28.08

Total Current Month's Credits

-\$28.08

Tampa Electric Usage History

Kilowatt-Hours Per Day (Average)

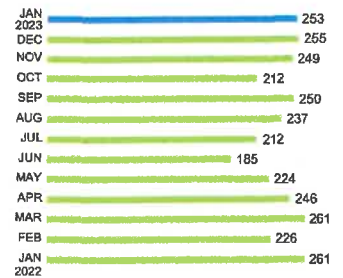

Billing Demand

(Kilowatts)



Load Factor

(Percentage)



Important Messages

Annual Deposit Interest Credit

This billing statement reflects your annual credit of deposit interest. Thank you for being a valued customer. We appreciate the opportunity to serve you.

Received

JAN 27 2023

ACCOUNT INVOICE

tampaelectric.com



Statement Date: 01/23/2023
Account: 221007645890

SOUTH FORK III COMMUNITY
11920 BRIGHTON KNOLL LP, FOUNTAIN
RIVERVIEW, FL 33579



Current month's charges:	\$623.88
Total amount due:	\$614.56
Payment Due By:	02/13/2023

Your Account Summary

Previous Amount Due	\$482.43
Payment(s) Received Since Last Statement	-\$482.43
Miscellaneous Credits	-\$9.32
Credit balance after payments and credits	-\$9.32
Current Month's Charges	\$623.88
Total Amount Due	\$614.56

00000025-0000551-Page 38 of 58

**Save Energy.
Save Money.**

It's never been easier with help from our many rebate programs for business.

tampaelectric.com/bizsave

Amount not paid by due date may be assessed a late payment charge and an additional deposit.

SCAM ALERT!

Scammers are calling. Don't be a victim.

- Scammers can alter caller ID numbers to make it look like TECO is calling.
- We will never ask you to purchase a prepaid card or download a payment app.
- **Know what you owe.** Reference your most recent bill or log in to your online account.
- If you think a call is a scam, hang up.

To learn more, or to report a scam, visit tampaelectric.com/scam

To ensure prompt credit, please return stub portion of this bill with your payment. Make checks payable to TECO.



WAYS TO PAY YOUR BILL



See reverse side for more information

Account: 221007645890

Current month's charges:	\$623.88
Total amount due:	\$614.56
Payment Due By:	02/13/2023

Amount Enclosed \$ _____
629161698282

SOUTH FORK III COMMUNITY
2005 PAN AM CIR, STE 300
TAMPA, FL 33607-6008

MAIL PAYMENT TO:
TECO
P.O. BOX 31318
TAMPA, FL 33631-3318

Account: 221007645890
Statement Date: 01/23/2023
Current month's charges due 02/13/2023



Details of Charges – Service from 12/15/2022 to 01/17/2023

Service for: 11920 BRIGHTON KNOLL LP, FOUNTAIN, RIVERVIEW, FL 33579

Rate Schedule: General Service - Non Demand

Meter Location: FOUNTAIN PUMP

0000025-000552-Page 41 of 58

Meter Number	Read Date	Current Reading	-	Previous Reading	=	Total Used	Multiplier	Billing Period
1000490200	01/17/2023	94,723		90,504		4,219 kWh	1	34 Days

Daily Basic Service Charge	34 days @ \$0.75000	\$25.50
Energy Charge	4,219 kWh @ \$0.07990/kWh	\$337.10
Fuel Charge	4,219 kWh @ \$0.04832/kWh	\$203.86
Storm Protection Charge	4,219 kWh @ \$0.00400/kWh	\$16.88
Clean Energy Transition Mechanism	4,219 kWh @ \$0.00427/kWh	\$18.02
Florida Gross Receipt Tax		\$15.42
Electric Service Cost		\$616.78
Other Fees and Charges		
Electric Late Payment Fee		\$7.10
Total Other Fees and Charges		\$7.10

Total Current Month's Charges **\$623.88**

Miscellaneous Credits

Interest for Cash Security Deposit - Electric -\$9.32

Total Current Month's Credits **-\$9.32**

Tampa Electric Usage History

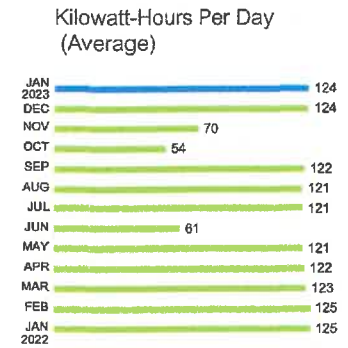

Important Messages

Annual Deposit Interest Credit

This billing statement reflects your annual credit of deposit interest. Thank you for being a valued customer. We appreciate the opportunity to serve you.

Change in Deposit Interest

This billing statement reflects a credit of 2 percent interest. This account has had an active deposit for 23 months and, in accordance with the Florida Public Service Commission rules, the interest rate on the deposit for this account has increased to 3 percent going forward.

Received

JAN 27 2023

ACCOUNT INVOICE

tampaelectric.com



Statement Date: 01/23/2023
Account: 221007876271

SOUTH FORK III COMMUNITY
SOUTH FORK AMENITY CENTER, LIGHTS
RIVERVIEW, FL 33578



Current month's charges:	\$519.44
Total amount due:	\$519.44
Payment Due By:	02/13/2023

Your Account Summary

Previous Amount Due	\$476.63
Payment(s) Received Since Last Statement	-\$476.63
Current Month's Charges	\$519.44
Total Amount Due	\$519.44

00000025-00000557-Page 51 of 98

**Save Energy.
Save Money.**

It's never been easier with help from our many rebate programs for business.

tampaelectric.com/bizsave

Amount not paid by due date may be assessed a late payment charge and an additional deposit.

SCAM ALERT!

Scammers are calling. Don't be a victim.

- Scammers can alter caller ID numbers to make it look like TECO is calling.
- We will never ask you to purchase a prepaid card or download a payment app.
- **Know what you owe.** Reference your most recent bill or log in to your online account.
- If you think a call is a scam, hang up.

To learn more, or to report a scam, visit tampaelectric.com/scam

To ensure prompt credit, please return stub portion of this bill with your payment. Make checks payable to TECO.

WAYS TO PAY YOUR BILL



See reverse side for more information

Account: 221007876271

Current month's charges:	\$519.44
Total amount due:	\$519.44
Payment Due By:	02/13/2023
Amount Enclosed	\$ _____

661260346452

SOUTH FORK III COMMUNITY
2005 PAN AM CIR, STE 300
TAMPA, FL 33607-6008

MAIL PAYMENT TO:
TECO
P.O. BOX 31318
TAMPA, FL 33631-3318

Account: 221007876271
Statement Date: 01/23/2023
Current month's charges due 02/13/2023



Details of Charges – Service from 12/15/2022 to 01/17/2023

Service for: SOUTH FORK AMENITY CENTER, LIGHTS, RIVERVIEW, FL 33578

Rate Schedule: Lighting Service

Lighting Service Items LS-1 (Bright Choices) for 34 days

Lighting Energy Charge	270 kWh @ \$0.03511/kWh	\$9.48
Fixture & Maintenance Charge	10 Fixtures	\$207.30
Lighting Pole / Wire	10 Poles	\$277.90
Lighting Fuel Charge	270 kWh @ \$0.04767/kWh	\$12.87
Storm Protection Charge	270 kWh @ \$0.01466/kWh	\$3.96
Clean Energy Transition Mechanism	270 kWh @ \$0.00036/kWh	\$0.10
Florida Gross Receipt Tax		\$0.68
Lighting Charges		\$512.29
Other Fees and Charges		
Lighting Late Payment Fee		\$7.15
Total Other Fees and Charges		\$7.15
Total Current Month's Charges		\$519.44

0000025-0000558-Page 53 of 98

Received

JAN 27 2023

ACCOUNT INVOICE

tampaelectric.com



Statement Date: 01/23/2023
Account: 221007953351

SOUTH FORK III COMMUNITY
AMBLESIDE DR AND PRADERA BLVD
RIVERVIEW, FL 33579



Current month's charges:	\$979.84
Total amount due:	\$979.84
Payment Due By:	02/13/2023

Your Account Summary

Previous Amount Due	\$900.39
Payment(s) Received Since Last Statement	-\$900.39
Current Month's Charges	\$979.84
Total Amount Due	\$979.84

0000025-000055-Page 47 of 56

**Save Energy.
Save Money.**

It's never been easier with help from our many rebate programs for business.

tampaelectric.com/bizsave

Amount not paid by due date may be assessed a late payment charge and an additional deposit.

SCAM ALERT!

Scammers are calling. Don't be a victim.

- Scammers can alter caller ID numbers to make it look like TECO is calling.
- We will never ask you to purchase a prepaid card or download a payment app.
- **Know what you owe.** Reference your most recent bill or log in to your online account.
- If you think a call is a scam, hang up.

To learn more, or to report a scam, visit tampaelectric.com/scam

To ensure prompt credit, please return stub portion of this bill with your payment. Make checks payable to TECO.

WAYS TO PAY YOUR BILL



See reverse side for more information

Account: 221007953351

Current month's charges:	\$979.84
Total amount due:	\$979.84
Payment Due By:	02/13/2023

Amount Enclosed \$

661260346453

SOUTH FORK III COMMUNITY
2005 PAN AM CIR, STE 300
TAMPA, FL 33607-6008

MAIL PAYMENT TO:
TECO
P.O. BOX 31318
TAMPA, FL 33631-3318

6612603464532210079533510000000979845

Account: 221007953351
Statement Date: 01/23/2023
Current month's charges due 02/13/2023



Details of Charges – Service from 12/15/2022 to 01/17/2023

Service for: AMBLESIDE DR AND PRADERA BLVD, RIVERVIEW, FL 33579

Rate Schedule: Lighting Service

Lighting Service Items LS-1 (Bright Choices) for 34 days

Lighting Energy Charge	399 kWh @ \$0.03511/kWh	\$14.01	
Fixture & Maintenance Charge	21 Fixtures	\$342.72	
Lighting Pole / Wire	21 Poles	\$583.59	
Lighting Fuel Charge	399 kWh @ \$0.04767/kWh	\$19.02	
Storm Protection Charge	399 kWh @ \$0.01466/kWh	\$5.85	
Clean Energy Transition Mechanism	399 kWh @ \$0.00036/kWh	\$0.14	
Florida Gross Receipt Tax		\$1.00	
Lighting Charges			\$966.33
Other Fees and Charges			
Lighting Late Payment Fee		\$13.51	
Total Other Fees and Charges			\$13.51
Total Current Month's Charges			\$979.84

0000025-000556-Page 49 of 58

Received

JAN 27 2023

ACCOUNT INVOICE

tampaelectric.com



Statement Date: 01/23/2023
Account: 221008035851

SOUTH FORK III COMMUNITY
AMBLESIDE DR AND PRADERA BL TRACT V
RIVERVIEW, FL 33569



Current month's charges:	\$2,659.57
Total amount due:	\$2,659.57
Payment Due By:	02/13/2023

Your Account Summary

Previous Amount Due	\$2,443.90
Payment(s) Received Since Last Statement	-\$2,443.90
Current Month's Charges	\$2,659.57
Total Amount Due	\$2,659.57

00000025-0000553-Page 43 of 58

**Save Energy.
Save Money.**

It's never been easier with help from our many rebate programs for business.

tampaelectric.com/bizsave

Amount not paid by due date may be assessed a late payment charge and an additional deposit.

SCAM ALERT!

Scammers are calling. Don't be a victim.

- Scammers can alter caller ID numbers to make it look like TECO is calling.
- We will never ask you to purchase a prepaid card or download a payment app.
- **Know what you owe.** Reference your most recent bill or log in to your online account.
- If you think a call is a scam, hang up.

To learn more, or to report a scam, visit tampaelectric.com/scam

To ensure prompt credit, please return stub portion of this bill with your payment. Make checks payable to TECO.

WAYS TO PAY YOUR BILL



See reverse side for more information

Account: 221008035851

Current month's charges:	\$2,659.57
Total amount due:	\$2,659.57
Payment Due By:	02/13/2023
Amount Enclosed	\$

661260346454

SOUTH FORK III COMMUNITY
2005 PAN AM CIR, STE 300
TAMPA, FL 33607-6008

MAIL PAYMENT TO:
TECO
P.O. BOX 31318
TAMPA, FL 33631-3318

6612603464542210080358510000002659574

Account: 221008035851
Statement Date: 01/23/2023
Current month's charges due 02/13/2023



Details of Charges – Service from 12/15/2022 to 01/17/2023

Service for: AMBLESIDE DR AND PRADERA BL TRACT V, RIVERVIEW, FL 33569 **Rate Schedule: Lighting Service**

Lighting Service Items LS-1 (Bright Choices) for 34 days

Lighting Energy Charge	1083 kWh @ \$0.03511/kWh	\$38.02
Fixture & Maintenance Charge	57 Fixtures	\$930.24
Lighting Pole / Wire	57 Poles	\$1584.03
Lighting Fuel Charge	1083 kWh @ \$0.04767/kWh	\$51.63
Storm Protection Charge	1083 kWh @ \$0.01466/kWh	\$15.88
Clean Energy Transition Mechanism	1083 kWh @ \$0.00036/kWh	\$0.39
Florida Gross Receipt Tax		\$2.72
Lighting Charges		\$2,622.91
Other Fees and Charges		
Lighting Late Payment Fee		\$36.66
Total Other Fees and Charges		\$36.66
Total Current Month's Charges		\$2,659.57

0000025-000554-Page 45 of 58

Received

JAN 27 2023

tampaelectric.com



Statement Date: 01/23/2023
Account: 221008114474

SOUTH FORK III COMMUNITY
11881 YELLOW VIOLET WAY, SIGN
RIVERVIEW, FL 33569



Current month's charges:	\$33.53
Total amount due:	\$32.76
Payment Due By:	02/13/2023

Your Account Summary

Previous Amount Due	\$24.67
Payment(s) Received Since Last Statement	-\$24.67
Miscellaneous Credits	-\$0.77
Credit balance after payments and credits	-\$0.77
Current Month's Charges	\$33.53
Total Amount Due	\$32.76

0000025-0000541-Page 19 of 58

**Save Energy.
Save Money.**

It's never been easier with help from our many rebate programs for business.

tampaelectric.com/bizsave

Amount not paid by due date may be assessed a late payment charge and an additional deposit.

SCAM ALERT!

Scammers are calling. Don't be a victim.

- Scammers can alter caller ID numbers to make it look like TECO is calling.
- We will never ask you to purchase a prepaid card or download a payment app.
- **Know what you owe.** Reference your most recent bill or log in to your online account.
- If you think a call is a scam, hang up.

To learn more, or to report a scam, visit tampaelectric.com/scam

To ensure prompt credit, please return stub portion of this bill with your payment. Make checks payable to TECO.



WAYS TO PAY YOUR BILL



See reverse side for more information

Account: 221008114474

Current month's charges:	\$33.53
Total amount due:	\$32.76
Payment Due By:	02/13/2023
Amount Enclosed	\$ _____

662494900872

SOUTH FORK III COMMUNITY
2005 PAN AM CIR, STE 300
TAMPA, FL 33607-6008

MAIL PAYMENT TO:
TECO
P.O. BOX 31318
TAMPA, FL 33631-3318

662494900872221008114474000000032766

Account: 221008114474
Statement Date: 01/23/2023
Current month's charges due 02/13/2023



Details of Charges – Service from 12/15/2022 to 01/17/2023

Service for: 11881 YELLOW VIOLET WAY, SIGN, RIVERVIEW, FL 33569

Rate Schedule: General Service - Non Demand

Meter Number	Read Date	Current Reading	-	Previous Reading	=	Total Used	Multiplier	Billing Period
1000597986	01/17/2023	161		144		17 kWh	1	34 Days

0000025-0000542- Page 21 of 38

Daily Basic Service Charge	34 days @ \$0.75000	\$25.50
Energy Charge	17 kWh @ \$0.07990/kWh	\$1.36
Fuel Charge	17 kWh @ \$0.04832/kWh	\$0.82
Storm Protection Charge	17 kWh @ \$0.00400/kWh	\$0.07
Clean Energy Transition Mechanism	17 kWh @ \$0.00427/kWh	\$0.07
Florida Gross Receipt Tax		\$0.71
Electric Service Cost		\$28.53
Other Fees and Charges		
Electric Late Payment Fee		\$5.00
Total Other Fees and Charges		\$5.00
Total Current Month's Charges		\$33.53

Tampa Electric Usage History

Kilowatt-Hours Per Day (Average)

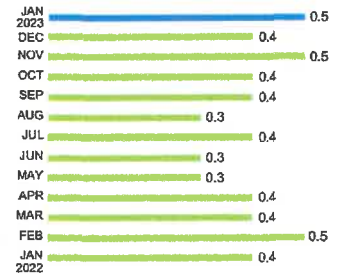

Miscellaneous Credits

Interest for Cash Security Deposit - Electric -\$0.77

Total Current Month's Credits **-\$0.77**

Important Messages

Annual Deposit Interest Credit

This billing statement reflects your annual credit of deposit interest. Thank you for being a valued customer. We appreciate the opportunity to serve you.

JAN 27 2023

Received

SOUTH FORK III COMMUNITY
11495 PRADERA RESERVE BLVD, SIGN
RIVERVIEW, FL 33579



Statement Date: 01/23/2023
Account: 221008114482

Current month's charges:	\$34.94
Total amount due:	\$34.15
Payment Due By:	02/13/2023

Your Account Summary

Previous Amount Due	\$30.65
Payment(s) Received Since Last Statement	-\$30.65
Miscellaneous Credits	-\$0.79
Credit balance after payments and credits	-\$0.79
Current Month's Charges	\$34.94
Total Amount Due	\$34.15

00000025-0000543-Page 23 of 36

**Save Energy.
Save Money.**

It's never been easier with help from our many rebate programs for business.

tampaelectric.com/bizsave

Amount not paid by due date may be assessed a late payment charge and an additional deposit.

SCAM ALERT!

Scammers are calling. Don't be a victim.

- Scammers can alter caller ID numbers to make it look like TECO is calling.
- We will never ask you to purchase a prepaid card or download a payment app.
- **Know what you owe.** Reference your most recent bill or log in to your online account.
- If you think a call is a scam, hang up.

To learn more, or to report a scam, visit tampaelectric.com/scam

To ensure prompt credit, please return stub portion of this bill with your payment. Make checks payable to TECO.



See reverse side for more information

Account: 221008114482

Current month's charges:	\$34.94
Total amount due:	\$34.15
Payment Due By:	02/13/2023

Amount Enclosed \$ _____

662494900873

SOUTH FORK III COMMUNITY
2005 PAN AM CIR, STE 300
TAMPA, FL 33607-6008

MAIL PAYMENT TO:
TECO
P.O. BOX 31318
TAMPA, FL 33631-3318

Account: 221008114482
Statement Date: 01/23/2023
Current month's charges due 02/13/2023



Details of Charges – Service from 12/15/2022 to 01/17/2023

Service for: 11495 PRADERA RESERVE BLVD, SIGN, RIVERVIEW, FL 33579

Rate Schedule: General Service - Non Demand

Meter Number	Read Date	Current Reading	-	Previous Reading	=	Total Used	Multiplier	Billing Period
1000597963	01/17/2023	320		293		27 kWh	1	34 Days

0000025-000544-Page 25 of 58

Daily Basic Service Charge	34 days @ \$0.75000	\$25.50
Energy Charge	27 kWh @ \$0.07990/kWh	\$2.16
Fuel Charge	27 kWh @ \$0.04832/kWh	\$1.30
Storm Protection Charge	27 kWh @ \$0.00400/kWh	\$0.11
Clean Energy Transition Mechanism	27 kWh @ \$0.00427/kWh	\$0.12
Florida Gross Receipt Tax		\$0.75
Electric Service Cost		\$29.94
Other Fees and Charges		
Electric Late Payment Fee		\$5.00
Total Other Fees and Charges		\$5.00
Total Current Month's Charges		\$34.94
Miscellaneous Credits		
Interest for Cash Security Deposit - Electric		-\$0.79
Total Current Month's Credits		-\$0.79

Tampa Electric Usage History

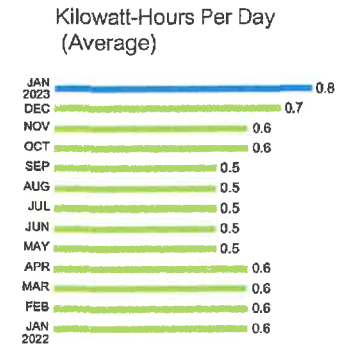

Important Messages

Annual Deposit Interest Credit

This billing statement reflects your annual credit of deposit interest. Thank you for being a valued customer. We appreciate the opportunity to serve you.

Received

JAN 27 2023

ACCOUNT INVOICE

tampaelectric.com



Statement Date: 01/23/2023
Account: 221008114490

SOUTH FORK III COMMUNITY
11545 PRADERA RESERVE BLVD, SIGN
RIVERVIEW, FL 33579



Current month's charges:	\$34.09
Total amount due:	\$33.31
Payment Due By:	02/13/2023

Your Account Summary

Previous Amount Due	\$30.28
Payment(s) Received Since Last Statement	-\$30.28
Miscellaneous Credits	-\$0.78
Credit balance after payments and credits	-\$0.78
Current Month's Charges	\$34.09
Total Amount Due	\$33.31

**Save Energy.
Save Money.**

It's never been easier with help from our many rebate programs for business.

tampaelectric.com/bizsave

0000025-000547-Page 31 of 38

Amount not paid by due date may be assessed a late payment charge and an additional deposit.

SCAM ALERT!

Scammers are calling. Don't be a victim.

- Scammers can alter caller ID numbers to make it look like TECO is calling.
- We will never ask you to purchase a prepaid card or download a payment app.
- **Know what you owe.** Reference your most recent bill or log in to your online account.
- If you think a call is a scam, hang up.

To learn more, or to report a scam, visit tampaelectric.com/scam

To ensure prompt credit, please return stub portion of this bill with your payment. Make checks payable to TECO.



WAYS TO PAY YOUR BILL



See reverse side for more information

Account: 221008114490

Current month's charges:	\$34.09
Total amount due:	\$33.31
Payment Due By:	02/13/2023
Amount Enclosed	\$ _____

662494900874

SOUTH FORK III COMMUNITY
2005 PAN AM CIR, STE 300
TAMPA, FL 33607-6008

MAIL PAYMENT TO:
TECO
P.O. BOX 31318
TAMPA, FL 33631-3318

6624949008742210081144900000000033311

Account: 221008114490
Statement Date: 01/23/2023
Current month's charges due 02/13/2023



Details of Charges – Service from 12/15/2022 to 01/17/2023

Service for: 11545 PRADERA RESERVE BLVD, SIGN, RIVERVIEW, FL 33579

Rate Schedule: General Service - Non Demand

Meter Number	Read Date	Current Reading	-	Previous Reading	=	Total Used	Multiplier	Billing Period
1000597988	01/17/2023	219		198		21 kWh	1	34 Days

0000025-0000548-Page 33 of 58

Daily Basic Service Charge	34 days @ \$0.75000	\$25.50
Energy Charge	21 kWh @ \$0.07990/kWh	\$1.68
Fuel Charge	21 kWh @ \$0.04832/kWh	\$1.01
Storm Protection Charge	21 kWh @ \$0.00400/kWh	\$0.08
Clean Energy Transition Mechanism	21 kWh @ \$0.00427/kWh	\$0.09
Florida Gross Receipt Tax		\$0.73
Electric Service Cost		\$29.09
Other Fees and Charges		
Electric Late Payment Fee		\$5.00
Total Other Fees and Charges		\$5.00
Total Current Month's Charges		\$34.09

Tampa Electric Usage History

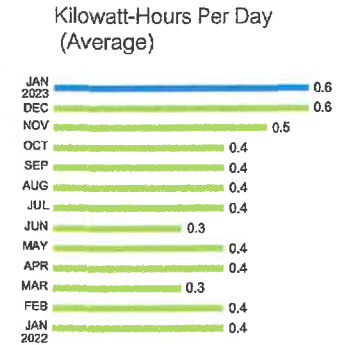

Miscellaneous Credits

Interest for Cash Security Deposit - Electric -\$0.78

Total Current Month's Credits **-\$0.78**

Important Messages

Annual Deposit Interest Credit

This billing statement reflects your annual credit of deposit interest. Thank you for being a valued customer. We appreciate the opportunity to serve you.

Received
JAN 27 2023

ACCOUNT INVOICE

tampaelectric.com | f t p g i n

Statement Date: 01/23/2023
Account: 221008126676

SOUTH FORK III COMMUNITY
11645 PRADERA RESERVE BL, SIGN
RIVERVIEW, FL 33579



Current month's charges:	\$32.14
Total amount due:	\$31.31
Payment Due By:	02/13/2023

Your Account Summary

Previous Amount Due	\$26.02
Payment(s) Received Since Last Statement	-\$26.02
Miscellaneous Credits	-\$0.83
Credit balance after payments and credits	-\$0.83
Current Month's Charges	\$32.14
Total Amount Due	\$31.31

**Save Energy.
Save Money.**

It's never been easier with help from our many rebate programs for business.

tampaelectric.com/bizsave

0000025-0000549-Page 35 of 58

Amount not paid by due date may be assessed a late payment charge and an additional deposit.

SCAM ALERT!

Scammers are calling. Don't be a victim.

- Scammers can alter caller ID numbers to make it look like TECO is calling.
- We will never ask you to purchase a prepaid card or download a payment app.
- **Know what you owe.** Reference your most recent bill or log in to your online account.
- If you think a call is a scam, hang up.

To learn more, or to report a scam, visit tampaelectric.com/scam

To ensure prompt credit, please return stub portion of this bill with your payment. Make checks payable to TECO.

WAYS TO PAY YOUR BILL



See reverse side for more information

Account: 221008126676

Current month's charges:	\$32.14
Total amount due:	\$31.31
Payment Due By:	02/13/2023

Amount Enclosed \$ _____
662494900875

SOUTH FORK III COMMUNITY
2005 PAN AM CIR, STE 300
TAMPA, FL 33607-6008

MAIL PAYMENT TO:
TECO
P.O. BOX 31318
TAMPA, FL 33631-3318

Account: 221008126676
Statement Date: 01/23/2023
Current month's charges due 02/13/2023



Details of Charges – Service from 12/15/2022 to 01/17/2023

Service for: 11645 PRADERA RESERVE BL, SIGN, RIVERVIEW, FL 33579

Rate Schedule: General Service - Non Demand

Meter Location: SIGN

0000025-000550-Page 37 of 58

Meter Number	Read Date	Current Reading	-	Previous Reading	=	Total Used	Multiplier	Billing Period
1000803036	01/17/2023	414		407		7 kWh	1	34 Days

Daily Basic Service Charge	34 days @ \$0.75000	\$25.50	
Energy Charge	7 kWh @ \$0.07990/kWh	\$0.56	
Fuel Charge	7 kWh @ \$0.04832/kWh	\$0.34	
Storm Protection Charge	7 kWh @ \$0.00400/kWh	\$0.03	
Clean Energy Transition Mechanism	7 kWh @ \$0.00427/kWh	\$0.03	
Florida Gross Receipt Tax		\$0.68	
Electric Service Cost		\$27.14	
Other Fees and Charges			
Electric Late Payment Fee		\$5.00	
Total Other Fees and Charges		\$5.00	
Total Current Month's Charges		\$32.14	

Tampa Electric Usage History

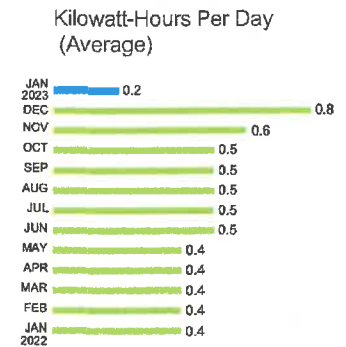

Miscellaneous Credits

Interest for Cash Security Deposit - Electric	-\$0.83
Total Current Month's Credits	-\$0.83

Important Messages

Annual Deposit Interest Credit

This billing statement reflects your annual credit of deposit interest. Thank you for being a valued customer. We appreciate the opportunity to serve you.



Invoice

Corporate Office
 PO Box 267
 Seffner, FL 33583

813-757-6500
 813-757-6501

Date	Invoice #
12/29/2022	172728

Bill To:
South Fork III CDD c/o Inframark 210 N University Dr #702 Coral Springs, FL 33071

Property Information

Estimate #
77924

Work Order #

PO / PA #

Description	Qty	Rate	Amount
<p>Proposal for removal only of dead palm trees. Tree locations as follow:</p> <ul style="list-style-type: none"> 2 - Mailbox park @ Galway Sand 1 - Mailbox park @ White Sapphire 1 - Stonewalk monument @ White Sapphire 1 - Avondale monument @ Billoming Dandelion 1 - Crestview monument @ Brighton Knoll 1 - Stonecrest monument @ Yellow Violet 1 - Sunstone Ridge monument @ Willow Bluestar 1 - Amenity Center <p>All work includes, clean-up, removal, and disposal of debris generated during the course of work.</p> <p>Note: Irrigation modifications necessary will be invoiced separately as 'time and materials' Bed Prep/ Debris/ Disposal</p>	9	735.00	6,615.00
Total			\$6,615.00
Questions regarding this invoice? Please e-mail arpayments@lmppro.com or call 813-757-6500 and ask for Accounts Receivable.	<i>Terms</i>	<i>Due Date</i>	Payments/Credits
	Net 30	1/28/2023	Balance Due
			\$6,615.00



PO Box 267
 Seffner, FL 33583
 O: 813-757-6500
 F: 813-757-6501

Estimate

Submitted To:
 South Fork III CDD
 c/o Inframark
 210 N University Dr #702
 Coral Springs, FL 33071

Date	6/3/2022
Estimate #	77927
LMP REPRESENTATIVE	
DM-TI	
PO #	
Work Order #	

[Empty box for additional information]

DESCRIPTION	QTY	COST	TOTAL
<p>Proposal for removal only of dead palm trees. Tree locations as follow:</p> <ul style="list-style-type: none"> 2 - Mailbox park @ Galway Sand 1 - Mailbox park @ White Sapphire 1 - Stonewalk monument @ White Sapphire 1 - Avondale monument @ Bloming Dandelion 1 - Crestview monument @ Brighton Knoll 1 - Stonecrest monument @ Yellow Violet 1 - Sunstone Ridge monument @ Willow Bluestar 1 - Amenity Center <i>right side</i> <p>All work includes, clean-up, removal, and disposal of debris generated during the course of work.</p> <p>Note: Irrigation modifications necessary will be invoiced separately as 'time and materials'</p> <p>Bed Prep/ Debris/ Disposal</p>	<p><i>All have caution tape</i></p> <p>9</p>	<p>735.00</p>	<p>6,615.00</p>

TERMS AND CONDITIONS:

TOTAL	\$6,615.00
--------------	-------------------

LMP reserves the right to withdraw this proposal if not accepted within 21 days of the date listed above. Any alteration or deviation to scope of work involving additional costs must be agreed upon in writing as a separate proposal or change order to this proposal. Periodic invoices may be submitted if job is substantial in nature with final invoice being submitted at completion of project. No finance charge will be imposed if the total of said work is paid in full within 30 days of invoice date. If not paid in full within 30 days, then customer is subject to finance charges on the balance of the work from the invoice date at a rate of 1.5% per month until paid. LMP shall have the right to stop work under this contract until all outstanding amounts including finance charges are paid in full. Payments will be applied to the oldest invoices.

ACCEPTANCE OF PROPOSAL: The above prices, scope of work and terms and conditions are hereby satisfactorily agreed upon. LMP, Inc. has been authorized to perform the work as outlined and payment will be made as outlined above. The above pricing does not include any unforeseen modifications to the said irrigation system that could not be reasonably accounted for prior to job start. All plant material carries a one (1) year warranty provided LMP, Inc. is performing landscape maintenance services to the area installed or enhanced at the time of installation. If not, then there is no warranty on the plant material. LMP cannot warranty against Acts of God, including cold weather events & natural disasters. Also, no warranty will be provided on any material that has been transplanted from another part of the property.

OWNER / AGENT



DATE



Invoice

Corporate Office
 PO Box 267
 Seffner, FL 33583

813-757-6500
 813-757-6501

Date	Invoice #
12/22/2022	172754

Bill To:
South Fork III CDD c/o Inframark 210 N University Dr #702 Coral Springs, FL 33071

Property Information

Estimate #
80723

Work Order #

PO / PA #
96910-96911

Description	Qty	Rate	Amount
The following proposal is for plant fill ins and or replacements: Stonecrest - 2 Monuments 14 - Shore Juniper for fill in at ground level planting bed 25 - Confetti Lantana for raised planters .68 - Top soil to raise/level with in the planter area .5 - Pine Bark Mini Nugget Mulch for ground level planting			
Sunstone Ridge - 4 Monuments 32 - Shore Juniper for fill in at ground level planting bed 49- Confetti Lantana for raised planters 1.36 - Top Soil to raise/level with in the planter area 1 - Pine Bark Mini Nugget Mulch for ground level planting			
Total			
Questions regarding this invoice? Please e-mail arpayments@lmppro.com or call 813-757-6500 and ask for Accounts Receivable.	Terms	Due Date	Payments/Credits
	Net 30	1/21/2023	Balance Due



Invoice

Corporate Office
 PO Box 267
 Seffner, FL 33583

813-757-6500
 813-757-6501

Date	Invoice #
12/22/2022	172754

Bill To:
South Fork III CDD c/o Inframark 210 N University Dr #702 Coral Springs, FL 33071

Property Information

Estimate #
80723

Work Order #

PO / PA #
96910-96911

Description	Qty	Rate	Amount
Avondale - 4 Monuments 52 - Shore Juniper for fill in at ground level planting bed 49 - Confetti Lantana for raised planters 1.36 - Top Soil to raise/level with in the planter area 1 - Pine Bark Mini Nugget Mulch for ground level planting			
Crestview - 6 Monuments 32 - Shore Juniper for fill in at ground level planting 36 - Liriope for fill in at ground level planting 73 - Confetti Lantana for raised planters 2 - Top Soil to raise/level with in the planter area 1.5 - Pine Bark Mini Nugget Mulch for ground level planting			
Total			
Questions regarding this invoice? Please e-mail arpayments@lmppro.com or call 813-757-6500 and ask for Accounts Receivable.	Terms	Due Date	Payments/Credits
	Net 30	1/21/2023	Balance Due



Invoice

Corporate Office
 PO Box 267
 Seffner, FL 33583

813-757-6500
 813-757-6501

Date	Invoice #
12/22/2022	172754

Bill To:
South Fork III CDD c/o Inframark 210 N University Dr #702 Coral Springs, FL 33071

Property Information

Estimate #
80723

Work Order #

PO / PA #
96910-96911

Description	Qty	Rate	Amount
Barrington - 2 Monuments 120 - Liriope for fill in at ground level planting 24 - Confetti Lantana for raised planters .68 - Top soil to raise/level with in the planter area .5 - Pine Bark Mini Nugget Mulch for ground level planting			
Stonewalk - 2 Monuments 54 - Liriope for fill in at ground level planting 24 - Confetti Lantana for raised planters .68 - Top soil to raise/level with in the planter area .5 - Pine Bark Mini Nugget Mulch for ground level planting			
Summerset - 2 Monuments 33 - Shore Juniper for fill in at ground level planting 24 - Confetti Lantana for raised planters .68 - Top soil to raise/level with in the planter area .5 - Pine Bark Mini Nugget Mulch for ground level planting			

		Total	
--	--	--------------	--

Questions regarding this invoice? Please e-mail arpayments@lmppro.com or call 813-757-6500 and ask for Accounts Receivable.	Terms	Due Date	Payments/Credits
	Net 30	1/21/2023	Balance Due



Invoice

Corporate Office
 PO Box 267
 Seffner, FL 33583

813-757-6500
 813-757-6501

Date	Invoice #
12/22/2022	172754

Bill To:
South Fork III CDD c/o Inframark 210 N University Dr #702 Coral Springs, FL 33071

Property Information

Estimate #
80723

Work Order #

PO / PA #
96910-96911

Description	Qty	Rate	Amount
All work includes, clean-up, removal, and disposal of debris generated during the course of work.			
Note: Irrigation modifications necessary will be invoiced separately as 'time and materials'			
Juniper - Dwarf Shore 3 gal.	163	26.78	4,365.14
Liriope - Muscari (Dwarf) 1 gal.	210	12.38	2,599.80
Lantana - confetti 1 gal.	268	13.30	3,564.40
Soil - Top Soil per cubic yard	8	146.25	1,170.00
Mulch - Pine Bark/ Super Mini (3cu)	54	17.15	926.10
Total			\$12,625.44
Questions regarding this invoice? Please e-mail arpayments@lmppro.com or call 813-757-6500 and ask for Accounts Receivable.	Terms	Due Date	Payments/Credits
	Net 30	1/21/2023	Balance Due
			\$0.00
			\$12,625.44



Invoice

Corporate Office
 PO Box 267
 Seffner, FL 33583

813-757-6500
 813-757-6501

Date	Invoice #
1/10/2023	172856

Bill To:
South Fork III CDD c/o Inframark 210 N University Dr #702 Coral Springs, FL 33071

Property Information

Estimate #

Work Order #

PO / PA #

Description	Qty	Rate	Amount
Irrigation repair completed on 1-9-2023 Irrigation parts Labor: 2 men @ \$ 115.00 per hour Located and replaced faulty Rainbird 24V solenoid.	1 0.5	71.33 115.00	71.33 57.50
Lift station controller - zone 17.		Total	\$128.83
Questions regarding this invoice? Please e-mail arpayments@lmppro.com or call 813-757-6500 and ask for Accounts Receivable.	Terms	Due Date	Payments/Credits
	Net 30	2/9/2023	Balance Due
			\$0.00
			\$128.83

Irrigation Service/Proposal Request

Property: *South for 3*

DATE *1-9-23*

Location

lift station clocks zone 17

Emergency? _____

Work Ordered By: _____

Field Contact if any: _____

Phone _____

FSR/PROPOSAL # _____

Description of Work to be performed:

replaced bad solenoid and repaired drip breaks.

Materials needed :

1-236239-67.99

2-PF-WCSTN-15- 1.67 = 3.34

12-TLCOVP- N/C

10feet-XFD0912- N/C

Foreman: *Dawick*

Manager _____

Date Completed _____

Total Man Hours _____

Inspected by _____

Date _____

Special Tools Needed:

Labor Rate 65/50

Labor 30 min

Labor: 57.50

total parts: 71.33

Grand total 128.83



Neptune Multi services LLC

11423 Crestlake Village Dr
 Riverview, FL, 33569
 Neptunemts@gmail.com
<https://www.facebook.com/101624548259772/posts/228424315579794/?sfnsn=mo>
 813-778-9857

Invoice

Invoice No: 0053267
Date: 01/23/2023
Terms: NET 0
Due Date: 01/23/2023

Bill To: South fork III CDD
 inframark@avidbill.com,
 mark.vega@inframark.com

Description	Quantity	Rate	Amount
South Fork III basket ball fence Stretch fence to top and bottom Tide fence to poles	1	\$425.00	\$425.00

Subtotal	\$425.00
TAX 0%	\$0.00
Total	\$425.00
Paid	\$0.00

Balance Due \$425.00

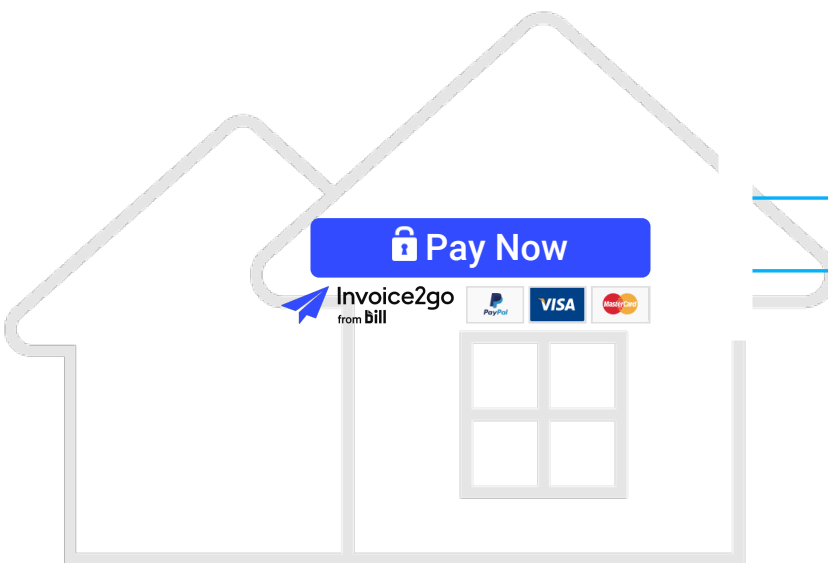

Neptune Multi services LLC - Invoice 0053267 - 01/23/2023

Please detach and send with remittance to:

Neptune Multi services LLC
11423 Crestlake Village Dr
Riverview, FL, 33569

Remittance Advice for Invoice # 0053267 on 01/23/2023

Balance Due \$425.00

Paid _____

Received From: South fork III CDD

Card Type			
Cardholder's Name	_____		
Card Number	<input type="text"/> <input type="text"/> <input type="text"/> <input type="text"/> <input type="text"/> <input type="text"/> <input type="text"/> <input type="text"/> <input type="text"/> <input type="text"/> <input type="text"/> <input type="text"/> <input type="text"/> <input type="text"/> <input type="text"/> <input type="text"/> <input type="text"/> <input type="text"/>	CVV	<input type="text"/> <input type="text"/> <input type="text"/>
Expiry Date	<input type="text"/> <input type="text"/> / <input type="text"/> <input type="text"/>		
Signature	<input type="text"/>		



CHECK REQUEST FORM
South Fork III

Date: 1/26/2023

Invoice#: 01052023-1

Vendor#: V00063

Vendor Name: South Fork III

Pay From: Truist Acct# 8694

Description: Series 2019 V & W - FY 23 Tax Dist. ID 606

Code to: 203.131000.1000

Amount: \$30,124.50

Requested By: Toni Campbell 1/26/2023

SOUTH FORK III CDD

DISTRICT CHECK REQUEST

Today's Date 1/5/2023
Check Amount \$30,124.50
Payable To South Fork III CDD
Check Description Series 2019 V & W - FY 23 Tax Dist. ID 606
Special Instructions Do not mail. Please give to Eric

(Please attach all supporting documentation: invoices, receipts, etc.)

Eric

Authorization

DM					
Fund		<u>001</u>			
G/L		<u>20702</u>			
Object Code					
Chk #			Date		

SOUTH FORK III CDD

TAX REVENUE RECEIPTS AND TRANSFER SCHEDULE
Fiscal Year 2023, Tax Year 2022

	Fiscal Year 2023 Percentages
Net O&M	38.111%
Net DS 16	20.970%
Net DS 18	3.114%
Net DS 19	37.805%
Net Total	100.00%

1,548,727.56

Date Received	Amount Received	38.11%		20.97%		3.11%		37.30%		37.80%		Proof	Date Transferred / Distribution ID	Notes / CDD check #	
		Raw Numbers Operations Revenue	Rounded Operations Revenue	Raw Numbers 2016 Debt Service Revenue	Rounded 2016 Debt Service Revenue	Raw Numbers 2018 Debt Service Revenue	Rounded 2018 Debt Service Revenue	Raw Numbers 2019 Debt Service Revenue	Rounded 2019 Debt Service Revenue						
11/3/2022	28,884.53	11,007.89	11,007.89	6,057.09	6,057.09	898.31	898.31	10,918.35	10,918.35	10,918.35	10,918.35	(2.89)	595	2520/	
11/16/2022	83,693.05	31,895.42	31,895.42	17,550.43	17,550.43	2,602.85	2,602.85	31,635.97	31,635.97	31,635.97	31,635.97	(8.38)	598	2523/2520/2520	
11/22/2022	49,086.33	18,707.29	18,707.29	10,293.40	10,293.40	1,528.55	1,528.55	18,557.09	18,557.09	18,557.09	18,557.09	-	599	2520	
11/28/2022	102,899.64	39,216.08	39,216.08	21,578.05	21,578.05	3,204.29	3,204.29	38,901.21	38,901.21	38,901.21	38,901.21	(0.01)	600	2555	
12/6/2022	2,502,427.84	953,700.27	953,700.27	524,759.12	524,759.12	77,925.60	77,925.60	946,042.84	946,042.84	946,042.84	946,042.84	(0.01)	602	2549	
12/13/2022	21,637.08	8,246.11	8,246.11	4,537.30	4,537.30	673.78	673.78	8,179.90	8,179.90	8,179.90	8,179.90	0.01	604	2563	
1/5/2023	79,683.90	30,368.33	30,368.33	16,709.71	16,709.71	2,481.36	2,481.36	30,124.50	30,124.50	30,124.50	30,124.50	-	606		
		-	-	-	-	-	-	-	-	-	-	-	-	-	
		-	-	-	-	-	-	-	-	-	-	-	-	-	
		-	-	-	-	-	-	-	-	-	-	-	-	-	
		-	-	-	-	-	-	-	-	-	-	-	-	-	
		-	-	-	-	-	-	-	-	-	-	-	-	-	
		-	-	-	-	-	-	-	-	-	-	-	-	-	
		-	-	-	-	-	-	-	-	-	-	-	-	-	
		-	-	-	-	-	-	-	-	-	-	-	-	-	
		-	-	-	-	-	-	-	-	-	-	-	-	-	
TOTAL	2,868,312.37	1,093,141.40	1,093,141.39	601,485.10	601,485.10	89,314.74	89,314.74	1,084,359.86	1,084,359.86	1,084,359.86	1,084,359.86	(11.28)			
Net Total on Roll Collection	2,908,399.87		1,108,423.46	609,897.47	609,897.47	90,572.68	90,572.68	1,099,506.25	1,099,506.25	1,099,506.25	1,099,506.25				
Surplus / (Deficit)	(40,087.50)		(15,282.07)	(8,412.37)	(8,412.37)	(1,257.94)	(1,257.94)	(15,146.39)	(15,146.39)	(15,146.39)	(15,146.39)				

CHECK REQUEST FORM
South Fork III

Date: 1/26/2023

Invoice#: 01052023-2

Vendor#: V00063

Vendor Name: South Fork III

Pay From: Truist Acct# 8694

Description: Series 2018 - FY 23 Tax Dist. ID 606

Code to: 202.131000.1000

Amount: \$2,481.36

Requested By: Toni Campbell 1/26/2023

SOUTH FORK III CDD

DISTRICT CHECK REQUEST

Today's Date 1/5/2023
Check Amount \$2,481.36
Payable To South Fork III CDD
Check Description Series 2018 - FY 23 Tax Dist. ID 606
Special Instructions Do not mail. Please give to Eric

(Please attach all supporting documentation: invoices, receipts, etc.)

Eric

Authorization

DM	
Fund	<u>001</u>
G/L	<u>20702</u>
Object Code	
Chk #	_____ Date _____

SOUTH FORK III CDD
TAX REVENUE RECEIPTS AND TRANSFER SCHEDULE
 Fiscal Year 2023, Tax Year 2022

1,548,727.56

Dollar Amounts	Fiscal Year 2023 Percentages
\$ 1,108,423.46	38.111%
\$ 609,897.47	20.970%
\$ 90,572.68	3.114%
\$ 1,099,506.25	37.805%
2,908,399.87	100.00%

Net O&M
 Net DS 16
 Net DS 18
 Net DS 19
 Net Total

Date Received	Amount Received	38.111%		20.97%		3.11%		37.80%		Proof	Date Transferred / Distribution ID	Notes / CDD check #
		Raw Numbers Operations Revenue	Rounded Operations Revenue	Raw Numbers 2016 Debt Service Revenue	Rounded 2016 Debt Service Revenue	Raw Numbers 2018 Debt Service Revenue	Rounded 2018 Debt Service Revenue	Raw Numbers 2019 Debt Service Revenue	Rounded 2019 Debt Service Revenue			
11/3/2022	28,884.53	11,007.89	11,007.89	6,057.09	6,057.09	898.31	898.31	10,918.35	10,918.35	(2.89)	595	2520/
11/16/2022	83,693.05	31,895.42	31,895.42	17,550.43	17,550.43	2,602.85	2,602.85	31,635.97	31,635.97	(8.38)	598	2523/2520/2520
11/22/2022	49,086.33	18,707.29	18,707.29	10,293.40	10,293.40	1,528.55	1,528.55	18,557.09	18,557.09	-	599	2520
11/28/2022	102,899.64	39,216.08	39,216.08	21,578.05	21,578.05	3,204.29	3,204.29	38,901.21	38,901.21	(0.01)	600	2555
12/6/2022	2,502,427.84	953,700.27	953,700.27	524,759.12	524,759.12	77,925.60	77,925.60	946,042.84	946,042.84	(0.01)	602	2549
12/13/2022	21,637.08	8,246.11	8,246.11	4,537.30	4,537.30	673.78	673.78	8,179.90	8,179.90	0.01	604	2563
1/5/2023	79,683.90	30,368.33	30,368.33	16,709.71	16,709.71	2,481.36	2,481.36	30,124.50	30,124.50	-	606	
		-	-	-	-	-	-	-	-	-	-	-
		-	-	-	-	-	-	-	-	-	-	-
		-	-	-	-	-	-	-	-	-	-	-
		-	-	-	-	-	-	-	-	-	-	-
		-	-	-	-	-	-	-	-	-	-	-
		-	-	-	-	-	-	-	-	-	-	-
		-	-	-	-	-	-	-	-	-	-	-
		-	-	-	-	-	-	-	-	-	-	-
		-	-	-	-	-	-	-	-	-	-	-
		-	-	-	-	-	-	-	-	-	-	-
		-	-	-	-	-	-	-	-	-	-	-
		-	-	-	-	-	-	-	-	-	-	-
TOTAL	2,868,312.37	1,093,141.40	1,093,141.39	601,485.10	601,485.10	89,314.74	89,314.74	1,084,359.86	1,084,359.86	(11.28)		
Net Total on Roll Collection	2,908,399.87		1,108,423.46		609,897.47		90,572.68		1,099,506.25			
Surplus / (Deficit)	(40,087.50)		(15,282.07)		(8,412.37)		(1,257.94)		(15,146.39)			

CHECK REQUEST FORM
South Fork III

Date: 1/26/2023

Invoice#: 01052023-3

Vendor#: V00063

Vendor Name: South Fork III

Pay From: Truist Acct# 8694

Description: Series 2016 - FY 23 Tax Dist. ID 606

Code to: 200.131000.1000

Amount: \$16,709.71

Requested By: Toni Campbell 1/26/2023

SOUTH FORK III CDD

DISTRICT CHECK REQUEST

Today's Date 1/5/2023
Check Amount \$16,709.71
Payable To South Fork III CDD
Check Description Series 2016 - FY 23 Tax Dist. ID 606
Special Instructions Do not mail. Please give to Eric

(Please attach all supporting documentation: invoices, receipts, etc.)

Eric

Authorization

DM					
Fund		<u>001</u>			
G/L		<u>20702</u>			
Object Code					
Chk #			Date		

SOUTH FORK III CDD
TAX REVENUE RECEIPTS AND TRANSFER SCHEDULE
 Fiscal Year 2023, Tax Year 2022

Dollar Amounts	Fiscal Year 2023 Percentages
\$ 1,108,423.46	38.111%
\$ 609,897.47	20.970%
\$ 90,572.68	3.114%
\$ 1,099,506.25	37.805%
2,908,399.87	100.00%

Net O&M
 Net DS 16
 Net DS 18
 Net DS 19
 Net Total

1,548,727.56

Date Received	Amount Received	38.11%		38.11%		20.97%		3.11%		3.11%		37.80%		Date Transferred / Distribution ID	Proof	Notes / CDD check #
		Raw Numbers Operations Revenue	Rounded Operations Revenue	Raw Numbers 2016 Debt Service Revenue	Rounded 2016 Debt Service Revenue	Raw Numbers 2018 Debt Service Revenue	Rounded 2018 Debt Service Revenue	Raw Numbers 2019 Debt Service Revenue	Rounded 2019 Debt Service Revenue							
11/3/2022	28,884.53	11,007.89	11,007.89	6,057.09	6,057.09	898.31	898.31	10,918.35	10,918.35	(2.89)	595		2520/			
11/16/2022	83,693.05	31,895.42	31,895.42	17,550.43	17,550.43	2,602.85	2,602.85	31,635.97	31,635.97	(8.38)	598		2523/2520/2520			
11/22/2022	49,086.33	18,707.29	18,707.29	10,293.40	10,293.40	1,528.55	1,528.55	18,557.09	18,557.09	-	599		2520			
11/28/2022	102,899.64	39,216.08	39,216.08	21,578.05	21,578.05	3,204.29	3,204.29	38,901.21	38,901.21	(0.01)	600		2555			
12/6/2022	2,502,427.84	953,700.27	953,700.27	524,759.12	524,759.12	77,925.60	77,925.60	946,042.84	946,042.84	(0.01)	602		2549			
12/13/2022	21,637.08	8,246.11	8,246.11	4,537.30	4,537.30	673.78	673.78	8,179.90	8,179.90	0.01	604		2563			
1/5/2023	79,683.90	30,368.33	30,368.33	16,709.71	16,709.71	2,481.36	2,481.36	30,124.50	30,124.50	-	606					
		-	-	-	-	-	-	-	-	-	-	-	-			
		-	-	-	-	-	-	-	-	-	-	-	-			
		-	-	-	-	-	-	-	-	-	-	-	-			
		-	-	-	-	-	-	-	-	-	-	-	-			
		-	-	-	-	-	-	-	-	-	-	-	-			
		-	-	-	-	-	-	-	-	-	-	-	-			
		-	-	-	-	-	-	-	-	-	-	-	-			
		-	-	-	-	-	-	-	-	-	-	-	-			
		-	-	-	-	-	-	-	-	-	-	-	-			
TOTAL	2,868,312.37	1,093,141.40	1,093,141.39	601,485.10	601,485.10	89,314.74	89,314.74	1,084,359.86	1,084,359.86	(11.28)						
Net Total on Roll Collection	2,908,399.87		1,108,423.46	609,897.47	609,897.47	90,572.68	90,572.68	1,099,506.25	1,099,506.25							
Surplus / (Deficit)	(40,087.50)		(15,282.07)	(8,412.37)	(8,412.37)	(1,257.94)	(1,257.94)	(15,146.39)	(15,146.39)							

CHECK REQUEST FORM
South Fork III

Date: 12/28/2022

Invoice#: 12132022-26

Vendor#: V00063

Vendor Name: South Fork III

Pay From: Truist Acct# 8694

Description: Series 2016 - FY 23 Tax Dist. ID 604

Code to: 200.131000.1000

Amount: \$4,537.30

Requested By: Toni Campbell 12/28/2022

SOUTH FORK III CDD
DISTRICT CHECK REQUEST

Today's Date 12/13/2022
Check Amount **\$4,537.30**
Payable To South Fork III CDD
Check Description Series 2016 - FY 23 Tax Dist. ID 604
Special Instructions Do not mail. Please give to Eric

(Please attach all supporting documentation: invoices, receipts, etc.)

Eric
Authorization

DM	
Fund	<u>001</u>
G/L	<u>20702</u>
Object Code	
Chk #	<u> </u> Date <u> </u>

SOUTH FORK III CDD

TAX REVENUE RECEIPTS AND TRANSFER SCHEDULE
Fiscal Year 2023, Tax Year 2022

	Dollar Amounts	Fiscal Year 2023 Percentages
Net O&M	\$ 1,108,423.46	38.111%
Net DS 16	\$ 609,897.47	20.970%
Net DS 18	\$ 90,572.68	3.114%
Net DS 19	\$ 1,099,506.25	37.805%
Net Total	2,908,399.87	100.00%

Date Received	Amount Received	38.11%	38.11%	20.97%	20.97%	3.11%	3.11%	37.80%	37.80%	Proof	Date Transferred / Distribution ID	Notes / CDD check #
		Raw Numbers Operations Revenue	Rounded Operations Revenue	Raw Numbers 2016 Debt Service Revenue	Rounded 2016 Debt Service Revenue	Raw Numbers 2018 Debt Service Revenue	Rounded 2018 Debt Service Revenue	Raw Numbers 2019 Debt Service Revenue	Rounded 2019 Debt Service Revenue			
11/3/2022	28,884.53	11,007.89	11,007.89	6,057.09	6,057.09	898.31	898.31	10,918.35	10,918.35	(2.89)	595	2520/2520
11/16/2022	83,693.05	31,895.42	31,895.42	17,550.43	17,550.43	2,602.85	2,602.85	31,635.97	31,635.97	(8.38)	598	2523/2520/2520
11/22/2022	49,086.33	18,707.29	18,707.29	10,293.40	10,293.40	1,528.55	1,528.55	18,557.09	18,557.09	-	599	2520
11/28/2022	102,899.64	39,216.08	39,216.08	21,578.05	21,578.05	3,204.29	3,204.29	38,901.21	38,901.21	(0.01)	600	
12/6/2022	2,502,427.84	953,700.27	953,700.27	524,759.12	524,759.12	77,925.60	77,925.60	946,042.84	946,042.84	(0.01)	602	
12/13/2022	21,637.08	8,246.11	8,246.11	4,537.30	4,537.30	673.78	673.78	8,179.90	8,179.90	0.01	604	
		-	-	-	-	-	-	-	-	-		
		-	-	-	-	-	-	-	-	-		
		-	-	-	-	-	-	-	-	-		
		-	-	-	-	-	-	-	-	-		
		-	-	-	-	-	-	-	-	-		
		-	-	-	-	-	-	-	-	-		
		-	-	-	-	-	-	-	-	-		
		-	-	-	-	-	-	-	-	-		
		-	-	-	-	-	-	-	-	-		
		-	-	-	-	-	-	-	-	-		
		-	-	-	-	-	-	-	-	-		
		-	-	-	-	-	-	-	-	-		
		-	-	-	-	-	-	-	-	-		
TOTAL	2,788,628.47	1,062,773.07	1,062,773.06	584,775.39	584,775.39	86,833.39	86,833.38	1,054,235.36	1,054,235.36	(11.28)		
Net Total on Roll Collection Surplus / (Deficit)	2,908,399.87 (119,771.40)		1,108,423.46 (45,650.40)	609,897.47 (25,122.08)	90,572.68 (3,739.30)	1,099,506.25 (45,270.89)						

CHECK REQUEST FORM
South Fork III

Date: 12/28/2022

Invoice#: 12132022-27

Vendor#: V00063

Vendor Name: South Fork III

Pay From: Truist Acct# 8694

Description: Series 2018 - FY 23 Tax Dist. ID 604

Code to: 202.131000.1000

Amount: \$673.78

Requested By: 12/28/2022
Toni Campbell

SOUTH FORK III CDD

DISTRICT CHECK REQUEST

Today's Date 12/13/2022
Check Amount \$673.78
Payable To South Fork III CDD
Check Description Series 2018 - FY 23 Tax Dist. ID 604
Special Instructions Do not mail. Please give to Eric

(Please attach all supporting documentation: invoices, receipts, etc.)

Eric

Authorization

DM				
Fund	<u>001</u>			
G/L	<u>20702</u>			
Object Code				
Chk #		Date		

SOUTH FORK III CDD

TAX REVENUE RECEIPTS AND TRANSFER SCHEDULE Fiscal Year 2023, Tax Year 2022

	Dollar Amounts	Fiscal Year 2023 Percentages
Net OR&M	\$ 1,108,423.46	38.111%
Net DS 16	\$ 609,897.47	20.970%
Net DS 18	\$ 90,572.68	3.114%
Net DS 19	\$ 1,099,506.25	37.805%
Net Total	2,908,399.87	100.00%

Date Received	Amount Received	38.11%		20.97%		3.11%		37.80%		Proof	Date Transferred / Distribution ID	Notes / CDD Check #
		Raw Numbers Operations Revenue	Rounded Operations Revenue	Raw Numbers 2016 Debt Service Revenue	Rounded 2016 Debt Service Revenue	Raw Numbers 2018 Debt Service Revenue	Rounded 2018 Debt Service Revenue	Raw Numbers 2019 Debt Service Revenue	Rounded 2019 Debt Service Revenue			
11/3/2022	28,884.53	11,007.89	11,007.89	6,057.09	6,057.09	898.31	898.31	10,918.35	10,918.35	(2.89)	595	2520/
11/16/2022	83,693.05	31,895.42	31,895.42	17,550.43	17,550.43	2,602.85	2,602.85	31,635.97	31,635.97	(8.38)	598	2523/2520/2520
11/22/2022	49,086.33	18,707.29	18,707.29	10,293.40	10,293.40	1,528.55	1,528.55	18,557.09	18,557.09	-	599	2520
11/28/2022	102,899.64	39,216.08	39,216.08	21,578.05	21,578.05	3,204.29	3,204.29	38,901.21	38,901.21	(0.01)	600	
1/6/2022	2,502,427.84	953,700.27	953,700.27	524,759.12	524,759.12	77,925.60	77,925.60	946,042.84	946,042.84	(0.01)	602	
12/13/2022	21,637.08	8,246.11	8,246.11	4,537.30	4,537.30	673.78	673.78	8,179.90	8,179.90	0.01	604	
		-	-	-	-	-	-	-	-	-		
		-	-	-	-	-	-	-	-	-		
		-	-	-	-	-	-	-	-	-		
		-	-	-	-	-	-	-	-	-		
		-	-	-	-	-	-	-	-	-		
		-	-	-	-	-	-	-	-	-		
		-	-	-	-	-	-	-	-	-		
		-	-	-	-	-	-	-	-	-		
		-	-	-	-	-	-	-	-	-		
		-	-	-	-	-	-	-	-	-		
TOTAL	2,788,628.47	1,062,773.07	1,062,773.06	584,775.39	584,775.39	86,833.39	86,833.38	1,054,235.36	1,054,235.36	(11.28)		
Net Total on Roll Collection	2,908,399.87		1,108,423.46		609,897.47		90,572.68		1,099,506.25			
Surplus / (Deficit)	(119,771.40)		(45,650.40)		(25,122.08)		(3,739.30)		(45,270.89)			

CHECK REQUEST FORM
South Fork III

Date: 12/28/2022

Invoice#: 12132022-28

Vendor#: V00063

Vendor Name: South Fork III

Pay From: Truist Acct# 8694

Description: Series 2019 V & W - FY 23 Tax Dist. ID 604

Code to: 203.131000.1000

Amount: \$8,179.90

Requested By: Toni Campbell 12/28/2022

SOUTH FORK III CDD
DISTRICT CHECK REQUEST

Today's Date 12/13/2022
Check Amount **\$8,179.90**
Payable To South Fork III CDD
Check Description Series 2019 V & W - FY 23 Tax Dist. ID 604
Special Instructions Do not mail. Please give to Eric

(Please attach all supporting documentation: invoices, receipts, etc.)

Eric
Authorization

DM	
Fund	<u>001</u>
G/L	<u>20702</u>
Object Code	
Chk #	<u> </u> Date <u> </u>

SOUTH FORK III CDD

TAX REVENUE RECEIPTS AND TRANSFER SCHEDULE Fiscal Year 2023, Tax Year 2022

Dollar Amounts	Fiscal Year 2023 Percentages	
Net O&M	\$ 1,108,423.46	38.111%
Net DS 16	\$ 609,897.47	20.970%
Net DS 18	\$ 90,572.68	3.114%
Net DS 19	\$ 1,099,506.25	37.805%
Net Total	2,908,399.87	100.00%

Date Received	Amount Received	38.11%	38.11%	20.97%	20.97%	3.11%	3.11%	37.80%	37.80%	Proof	Date Transferred / Distribution ID	Notes / CDD check #
		Raw Numbers Operations Revenue	Rounded Operations Revenue	Raw Numbers 2016 Debt Service Revenue	Rounded 2016 Debt Service Revenue	Raw Numbers 2018 Debt Service Revenue	Rounded 2018 Debt Service Revenue	Raw Numbers 2019 Debt Service Revenue	Rounded 2019 Debt Service Revenue			
11/3/2022	28,884.53	11,007.89	11,007.89	6,057.09	6,057.09	898.31	898.31	10,918.35	10,918.35	(2.89)	595	2520/
11/16/2022	83,693.05	31,895.42	31,895.42	17,550.43	17,550.43	2,602.85	2,602.85	31,635.97	31,635.97	(8.38)	598	2523/2520/2520
11/22/2022	49,086.33	18,707.29	18,707.29	10,293.40	10,293.40	1,528.55	1,528.55	18,557.09	18,557.09	-	599	2520
11/28/2022	102,899.64	39,216.08	39,216.08	21,578.05	21,578.05	3,204.29	3,204.29	38,901.21	38,901.21	(0.01)	600	
12/6/2022	2,502,427.84	953,700.27	953,700.27	524,759.12	524,759.12	77,925.60	77,925.60	946,042.84	946,042.84	(0.01)	602	
12/13/2022	21,637.08	8,246.11	8,246.11	4,537.30	4,537.30	673.78	673.78	8,179.90	8,179.90	0.01	604	
		-	-	-	-	-	-	-	-	-		
		-	-	-	-	-	-	-	-	-		
		-	-	-	-	-	-	-	-	-		
		-	-	-	-	-	-	-	-	-		
		-	-	-	-	-	-	-	-	-		
		-	-	-	-	-	-	-	-	-		
		-	-	-	-	-	-	-	-	-		
		-	-	-	-	-	-	-	-	-		
		-	-	-	-	-	-	-	-	-		
		-	-	-	-	-	-	-	-	-		
		-	-	-	-	-	-	-	-	-		
		-	-	-	-	-	-	-	-	-		
		-	-	-	-	-	-	-	-	-		
TOTAL	2,788,628.47	1,062,773.07	1,062,773.06	584,775.39	584,775.39	86,833.39	86,833.38	1,054,235.36	1,054,235.36	(11.28)		
Net Total on Roll Collection	2,908,399.87		1,108,423.46		609,897.47		90,572.68		1,099,506.25			
Surplus / (Deficit)	(119,771.40)		(45,650.40)		(25,122.08)		(3,739.30)		(45,270.89)			

Invoice Number	2030134
Invoice Date	January 12, 2023
Purchase Order	215612970
Customer Number	135309
Project Number	215612970

Bill To

South Fork III CDD
 Accounts Payable
 c/o Inframark
 210 North University Drive, Suite 702
 Coral Springs FL 33071
 United States

Please Remit To

Stantec Consulting Services Inc. (SCSI)
 13980 Collections Center Drive
 Chicago IL 60693
 United States

Project	South Fork III CDD			
	Project Manager	Stewart, Tonja L	For Period Ending	December 30, 2022
	Current Invoice Total (USD)	244.00		

Discussions regarding community mapping

Top Task **2023** **2023 FY General Consulting**

Professional Services

Category/Employee		Current Hours	Rate	Current Amount
	Nurse, Vanessa M	0.25	144.00	36.00
	Stewart, Tonja L	1.00	208.00	208.00
	Subtotal Professional Services	<u>1.25</u>		<u>244.00</u>

Top Task Subtotal	2023 FY General Consulting	244.00
	Total Fees & Disbursements	<u>244.00</u>
	INVOICE TOTAL (USD)	244.00

Due upon receipt or in accordance with terms of the contract

Please contact Summer Fillinger if you have any questions concerning this invoice.

Phone: (262) 241-8222 [E-mail: Summer.Fillinger@Stantec.com](mailto:Summer.Fillinger@Stantec.com)

**** PLEASE SEND AN INVOICE # WITH PAYMENT ****

Thank you.



tampabay.com

Times Publishing Company
 DEPT 3396
 PO BOX 123396
 DALLAS, TX 75312-3396
 Toll Free Phone: 1 (877) 321-7355
 Fed Tax ID 59-0482470

ADVERTISING INVOICE

Advertising Run Dates		Advertiser Name	
01/ 4/23		SOUTH FORK III CDD C/O MERITUS	
Billing Date	Sales Rep	Customer Account	
01/04/2023	Jessica Attard	84558	
Total Amount Due		Ad Number	
\$520.50		0000265087	

PAYMENT DUE UPON RECEIPT

Start	Stop	Ad Number	Product	Placement	Description PO Number	Ins.	Size	Net Amount
01/04/23	01/04/23	0000265087	Times	Legals CLS	RFP Landscape Maintenance Services	1	2x62 L	\$518.50
01/04/23	01/04/23	0000265087	Tampabay.com	Legals CLS	RFP Landscape Maintenance Services AffidavitMaterial	1	2x62 L	\$0.00 \$2.00

Received
 JAN 09 2023

PLEASE DETACH AND RETURN LOWER PORTION WITH YOUR REMITTANCE



tampabay.com

DEPT 3396
 PO BOX 123396
 DALLAS, TX 75312-3396
 Toll Free Phone: 1 (877) 321-7355

Advertising Run Dates		Advertiser Name	
01/ 4/23		SOUTH FORK III CDD C/O MERITUS	
Billing Date	Sales Rep	Customer Account	
01/04/2023	Jessica Attard	84558	
Total Amount Due		Ad Number	
\$520.50		0000265087	

ADVERTISING INVOICE

Thank you for your business.

DO NOT SEND CASH BY MAIL

PLEASE MAKE CHECK PAYBLE TO: TIMES PUBLISHING COMPANY

SOUTH FORK III CDD C/O MERITUS
 2005 PAN AM CIRCLE #300
 TAMPA, FL 33607

REMIT TO:

Times Publishing Company
 DEPT 3396
 PO BOX 123396
 DALLAS, TX 75312-3396

Tampa Bay Times

Published Daily

STATE OF FLORIDA
COUNTY OF Hillsborough

Before the undersigned authority personally appeared **Judy Allen** who on oath says that he/she is **Legal Advertising Representative** of the **Tampa Bay Times** a daily newspaper printed in St. Petersburg, in Pinellas County, Florida; that the attached copy of advertisement, being a Legal Notice in the matter **RE: RFP Landscape Maintenance Services** was published in said newspaper by print in the issues of: **1/ 4/23** or by publication on the newspaper's website, if authorized, on

Affiant further says the said **Tampa Bay Times** is a newspaper published in **Hillsborough** County, Florida and that the said newspaper has heretofore been continuously published in said **Hillsborough** County, Florida each day and has been entered as a second class mail matter at the post office in said **Hillsborough** County, Florida for a period of one year next preceding the first publication of the attached copy of advertisement, and affiant further says that he/she neither paid not promised any person, firm or corporation any discount, rebate, commission or refund for the purpose of securing this advertisement for publication in the said newspaper.

Signature Affiant

Sworn to and subscribed before me this **01/04/2023**

Signature of Notary Public

Personally known X or produced identification

Type of identification produced _____

South Fork III Community Development District Request for Proposals for Landscape Maintenance Services

The South Fork III Community Development District (the "District") hereby requests proposals to provide services relating to landscape maintenance services. The RFP Package will be available beginning on January 4th, by emailing the District Manager, Mark Vega at Mark.vega@inframark.com.

} ss

Rankings will be made based on the Evaluation Criteria contained within the RFP Package. Price will be one factor used in determining the proposal that is in the best interest of the District, but the District explicitly reserves the right to make such award to other than the lowest price proposal. The District has the right to reject any and all proposals and waive any technical errors, informalities or irregularities if it determines in its discretion that it is in the best interest of the District to do so.

A mandatory pre-proposal meeting will be held on **Wednesday, January 11, 2023, at 10:00 a.m. (EST), at South Fork III Clubhouse located at 11771 Ambleside Blvd., Riverview, FL 33579**. In order to submit a proposal, each Proposer must (1) be authorized to do business in Florida and hold all required state and federal licenses in good standing; (2) have at least five (5) years of experience with landscape and irrigation maintenance projects; and (3) attend the mandatory pre-proposal meeting. Copies of the RFP Package will not be available at the pre-proposal meeting.

Any and all questions relative to this project shall be directed in writing to the Mark Vega at Mark.vega@inframark.com. **The deadline for submitting questions relative to this project is 5:00 p.m. on January 18, 2023.**

Firms desiring to provide services for this project must submit seven (7) hardcopies of the proposal **no later than 5:00 p.m. on January 25, 2023, at the South Fork III Clubhouse located at 11771 Ambleside Blvd., Riverview, FL 33579**. Proposals shall be submitted in a sealed opaque package, shall bear the name of the proposer on the outside of the package, and shall identify the name of the District. Proposals will be publicly opened at the time and date stipulated above; those received after the time and date stipulated above may be returned unopened to the Proposer. Any proposal not completed as specified or missing the required proposal documents may be disqualified.

Any person or firm who is affected by a District decision to award a contract shall an initial written notice of protest within seventy-two (72) hours of the time of the District's decision. The written formal protest setting forth with particularity the facts and law upon which the protest is based shall be filed within seven (7) calendar days after the initial notice of protest is filed. Failure to timely file an initial notice of protest or failure to timely file a formal written protest shall constitute a waiver of any right to object or protest. Additional information and requirements regarding protests are set forth in the District's Rules of Procedure, which are available from the District Manager via email.

Mark Vega
District Manager

Publication Date: January 4, 2023

0000265087

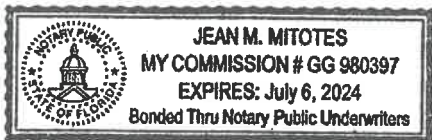

DISTRICT CHECK REQUEST FORM

Today's Date **January 10, 2023**

District Name **South Fork III CDD**

Check Amount **\$200,000.00**

Payable: **South Fork III Community Association**

Mailing Address **2005 Pan Am Circle Suite 300**
Tampa, FL 33607

Check Description **repayment of loan from the HOA to the CDD**

Special Instructions

(Please attach all support documentation: i.e., invoices, training class applications, etc.)

Mark Vega
Approved Signature

DM					
Fund					
G/L					
Object Cd					
CK #		Date			

Operating Cash-CIT Bank

South Fork 111 Community Association, Inc.

2005 Pan Am Circle
Tampa, FL 33607

CIT Bank

PO Box 60095
Phoenix, AZ 85082

2002

PAY ****TWO HUNDRED THOUSAND DOLLARS AND 00/100 ****

DATE AMOUNT
8/31/2022 \$200,000.00

TO THE ORDER OF

South Fork III CDD
2005 Pan Am Circle
Suite 300
Tampa, FL 33607

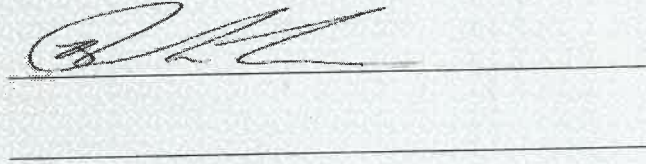

SECURITY FEATURES INCLUDED. DETAILS ON BACK

⑈002002⑈ ⑆104002894⑆ 275637035⑈

South Fork 111 Community Association, Inc. 8/31/2022 Chk#: 2002 \$200,000.00 CIT Bank
South Fork III CDD Notes / Loans Payable

Type	Amount	Invoice #	Invoice Date	Memo
2050 Notes / Loans Payabl	200,000.00	LOAN TO SOU1	8/31/2022	
	200,000.00			

South Fork 111 Community Association, Inc. 8/31/2022 Chk#: 2002 \$200,000.00 CIT Bank
South Fork III CDD Notes / Loans Payable

Type	Amount	Invoice #	invoice Date	Memo
2050 Notes / Loans Payabl	200,000.00	LOAN TO SOU1	8/31/2022	
	200,000.00			

**ACTION BY UNANIMOUS WRITTEN CONSENT
OF BOARD OF DIRECTORS OF
SOUTH FORK III COMMUNITY ASSOCIATION, INC.**

WHEREAS, Florida Statutes Section 617.0302(13) states that "Every corporation not for profit organized under this chapter, unless otherwise provided in its articles of incorporation or bylaws, shall have power to: . . .Lend money for its corporate purposes, invest and reinvest its funds, and take and hold real and personal property as security for the payment of funds loaned or invested except as prohibited by s. 617.0833";

WHEREAS, the Association's Articles of Incorporation and Bylaws do not prohibit or place any restrictions on lending;

WHEREAS, pursuant to Florida Statutes Chapter 617.0821 and the Association's Bylaws Section 4.5, the Board desires to take this action by unanimous written consent;

NOW, THEREFORE, BE IT RESOLVED that, pursuant to applicable law, the undersigned, being all of the Directors of this Board, hereby consent to, approve, and adopt the following:

- That the Association will lend \$200,000.00 to the South Fork III Community Development District pursuant to the Fiscal Year 2022/2023 Funding Agreement attached hereto as Exhibit "A."

This Unanimous Written Consent may be executed in one or more counterparts, each of which shall be an original and all of which together shall be one and the same instrument. This Unanimous Written Consent shall be filed in the Minute Book of this corporation and become a part of the records of this corporation.

Date: August 22, 2022

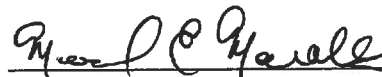
Manuel E. Morales, President

Christine A. Ford, Vice President

Scott D. Corder, Secretary / Treasurer

IN WITNESS WHEREOF, the parties execute this Agreement the day and year first written above.

Attest:

SOUTH FORK III COMMUNITY DEVELOPMENT DISTRICT

By: Mark A Vega
Name: Mark A Vega
Secretary/Assistant Secretary

By: [Signature]
Name: Nicholas T. Diste
Chair/Vice Chair of the Board of Supervisors

Witnesses:

SOUTH FORK III COMMUNITY ASSOCIATION, INC., a Florida not for profit corporation

By: Christine A. Ford
Name: Christine A. Ford

By: Susan Peltz
Name: SUSAN PELTZ

By: Manuel E Morales
Name: Manuel E Morales
Title: HOA President

**Exhibit "A" – Fiscal Year 2021/2022 General Fund Budget
Fiscal Year 2022/2023 Proposed General Fund Budget**

Fiscal Year 2021/2022 and 2022/2023 Funding Agreement

This Fiscal Year 2021/2022 and 2022/2023 Funding Agreement (the “**Agreement**”) is made and entered into this 4th day of August, 2022, by and between the **South Fork III Community Development District**, a local unit of special-purpose government established pursuant to Chapter 190, Florida Statutes, whose mailing address is 2005 Pan Am Circle, Suite 300, Tampa, Florida 33607 (the “**District**”), and **South Fork III Community Association, Inc.**, a Florida not for profit corporation whose address is 2005 Pan Am Circle, Suite 300, Tampa, FL 33607 (the “**HOA**”).

WHEREAS, the District is a local unit of special-purpose government established pursuant to Chapter 190, Florida Statutes and located in Hillsborough County, Florida, for the purpose of planning, financing, constructing, operating and/or maintaining certain infrastructure; and

WHEREAS, the District, pursuant to Chapter 190, Florida Statutes, is authorized to levy such taxes, special assessments, fees and other charges as may be necessary in furtherance of the District's activities and services; and

WHEREAS, the District has adopted its general fund budget for the Fiscal Year 2021/2022, which year commences on October 1, 2021 and concludes on September 30, 2022, and has approved its proposed general fund budget for the Fiscal Year 2022/2023, (collectively, the “**Budget**”); and

WHEREAS, the District will need a funding mechanism to enable it to proceed with its operation and maintenance services during the last quarter of Fiscal Year 2021/2023 and the first quarter of Fiscal Year 2022/2023, as described in the Budget attached hereto and incorporated herein as **Exhibit “A”**; and

WHEREAS, the HOA desires to provide such funds as are necessary to the District to proceed with its operations and maintenance services for the last quarter of Fiscal Year 2021/2022 and the first quarter of Fiscal Year 2022/2023, as described in the Budget, and as may be amended from time to time by the District; and

WHEREAS, the District finds that this Agreement is necessary and proper for the benefit of the District and agrees to repay the funds to the HOA in accordance with the terms of this Agreement.

Now, therefore, based upon good and valuable consideration and the mutual covenants of the parties, the receipt and sufficiency of which are hereby acknowledged, the parties agree as follows:

1. Funding Obligations. The HOA agrees to make available to the District the aggregate sum of Two Hundred Thousand and 00/100 Dollars (\$200,000.00) (the “Funds”) upon execution of this Agreement by both parties for the purpose of funding the operation and maintenance obligations of the District in accordance with the Budget as such expenses are incurred by the District. All Funds provided hereunder shall be placed in the District's general operating account.

2. Repayment. The District and the HOA understand and agree that this Agreement shall be payable solely from operation and maintenance assessments ("O&M Assessments") levied by the District for Fiscal Year 2022/2023 on each of the assessable properties located within the district and collected by the Hillsborough County Tax Collector pursuant to Fla. Stat. §197.3632. The Funds shall be due and payable in full in the amount of Two Hundred Thousand and 00/100 Dollars (\$200,000.00), plus administrative costs, by the District on December 31, 2022, so long as the District has received distributions of O&M Assessments from the Hillsborough County Tax Collector sufficient to pay such amount in full. If the District has not received sufficient distributions of O&M Assessments to pay the full outstanding principal by December 31, 2022, the District shall pay to the HOA (i) the total amount of O&M Assessments for Fiscal Year 2022/2023 received by the District as of December 31, 2022 no later than five (5) days after December 31, 2022 and (ii) the total amount of O&M Assessments for fiscal year 2021/2022 subsequently received by the District as of the last day of each calendar month thereafter no later than five (5) days from the end of such calendar month until the District has repaid the Funds in full.

3. Administrative Costs. The District shall pay to the HOA administrative costs in the amount of ~~Ten Thousand and 00/100 Dollars (\$10,000.00)~~, which shall be added to the Funds to be repaid as set forth in Section 2 of this Agreement. *Zero M&V* *Zero M&V*

4. Amendments. This instrument constitutes the final and complete expression of the agreement between the parties relating to the subject matter of this Agreement. Amendments to and waivers of the provisions contained in this Agreement may be made only by an instrument in writing which is executed by both of the parties hereto.

5. Authority. The execution of this Agreement has been duly authorized by the appropriate body or official of all parties hereto, each party has complied with all the requirements of law, and each party has full power and authority to comply with the terms and provisions of this instrument.

6. Assignment. This Agreement may be assigned, in whole or in part, by either party only upon the written consent of the other, which consent shall not be unreasonably withheld.

7. Default. A default by either party under this Agreement shall entitle the other to all remedies available at law or in equity, which shall include, but not be limited to, the right to seek specific performance of the HOA's payment obligations under this Agreement, but shall not include special, consequential, or punitive damages.

8. Third Parties. This Agreement is solely for the benefit of the parties hereto and no right or cause of action shall accrue upon or by reason hereof, to or for the benefit of any third party not a formal party hereto. Nothing in this Agreement expressed or implied is intended or shall be construed to confer upon any person or corporation other than the parties hereto any right, remedy or claim under or by reason of this Agreement or any provisions or conditions hereof; and all of the provisions, representations, covenants and conditions herein contained shall inure to the sole benefit of and shall be binding upon the parties hereto and their respective representatives, successors and assigns.

9. Governing Law. This Agreement and the provisions contained herein shall be construed, interpreted and controlled according to the laws of the State of Florida with venue in Hillsborough County, Florida.

10. Interpretation. This Agreement has been negotiated fully between the parties as an arm's length transaction. The parties participated fully in the preparation of this Agreement with the assistance of their respective counsel. In the case of a dispute concerning the interpretation of any provision of this Agreement, the parties are each deemed to have drafted, chosen and selected the language, and the doubtful language will not be interpreted or construed against any party.

11. Termination of Agreement. The Agreement shall be effective upon execution by both parties hereto and shall remain in force until the funds received from the HOA have been repaid by the District in accordance with the provisions of Section 2 herein, or the end of the 2022/2023 fiscal year on September 30, 2023, whichever comes first. The enforcement provisions of this Agreement shall survive its termination, until all payments due under this Agreement are paid in full.

12. Costs and Fees. In the event either party is required to enforce this Agreement, then the prevailing party shall be entitled to all fees and costs, including reasonable attorney's fees and costs, from the non-prevailing party.

[SIGNATURE PAGE TO FOLLOW]

O:\CIVIL\4802\502\005\Production\Drawings\KNS\SWMA\AMBLESIDE.dwg
 © COPYRIGHT 2016 KING ENGINEERING ASSOCIATES, INC. DRAWINGS AND CONCEPTS MAY NOT BE USED OR REPRODUCED WITHOUT WRITTEN PERMISSION. KING ENGINEERING ASSOCIATES, INC. IS AN EQUAL OPPORTUNITY EMPLOYER.

AMBLESIDE BLVD CURVE TABLE								
CURVE NUMBER	PI STA.	Δ	TANGENT	LENGTH	RADIUS	PC STA.	PT STA.	e
C2	104+13.99	36.8774	1000.22'	1930.89'	3000', (1.9099)	94+13.77	113+44.66	NC

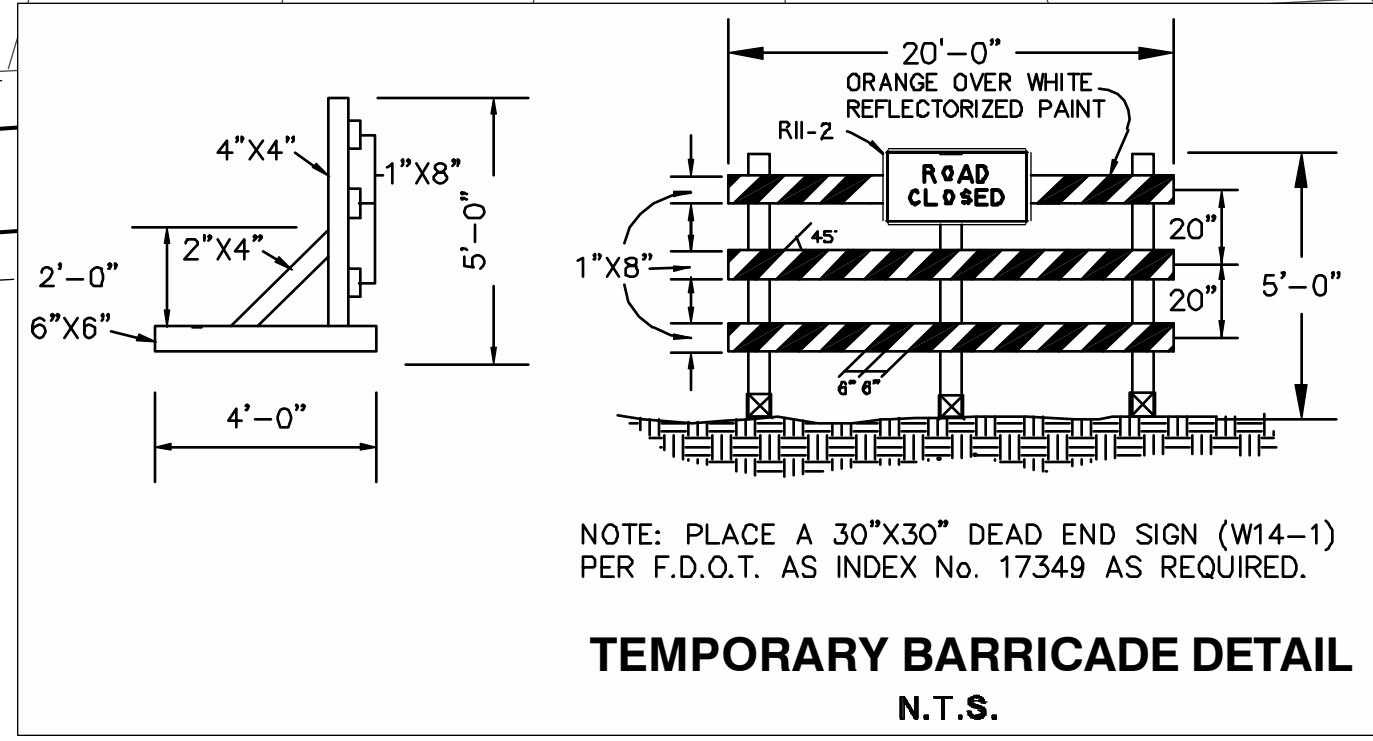
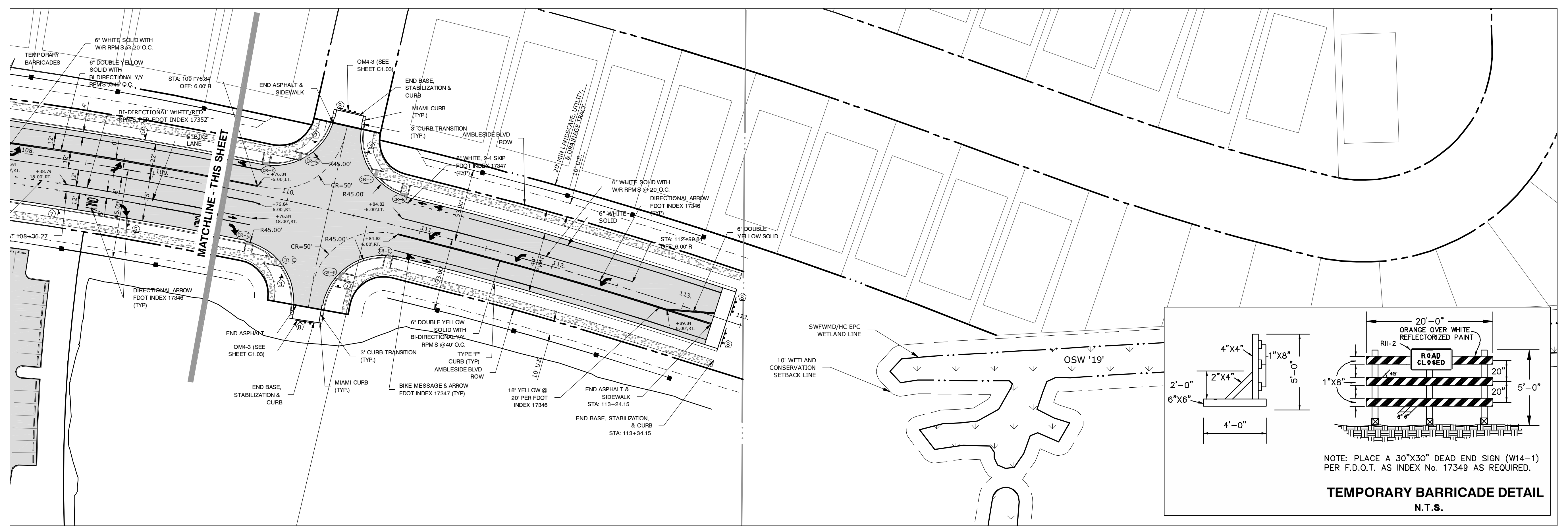
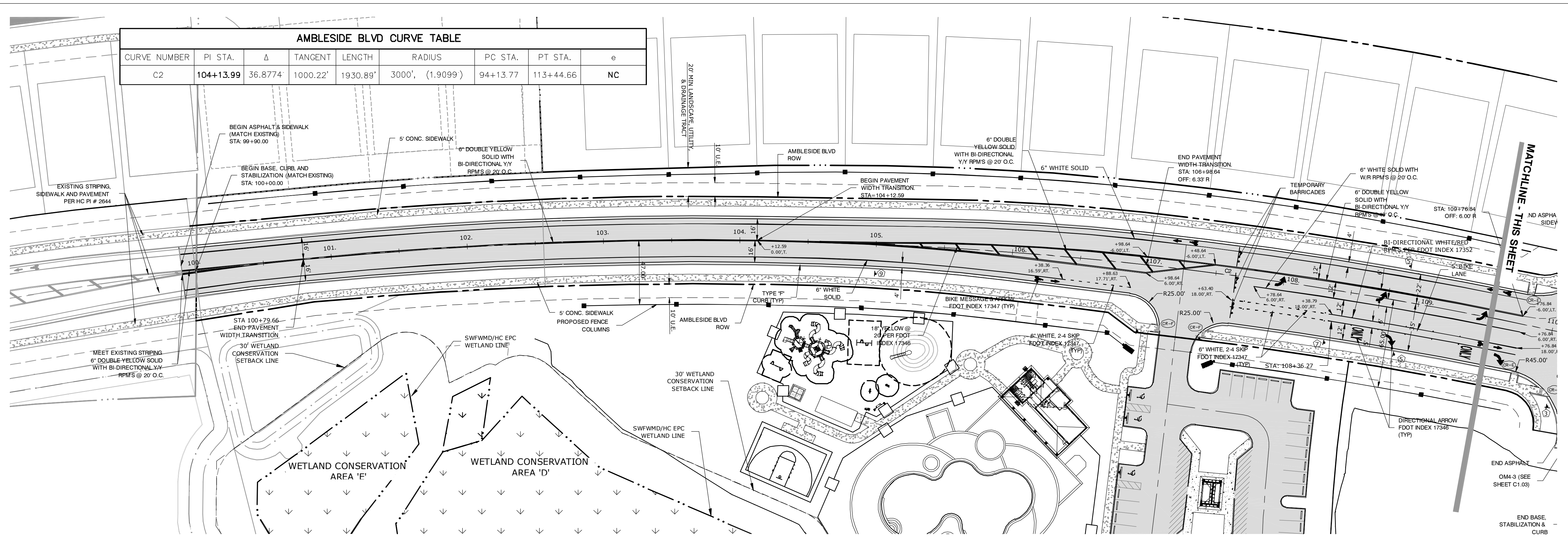

PERMITTED DRAWINGS SOUTHWEST FLORIDA WATER MANAGEMENT DISTRICT (SWFWMD)
 For construction permits, the Permittees shall notify the District in writing when construction begins.

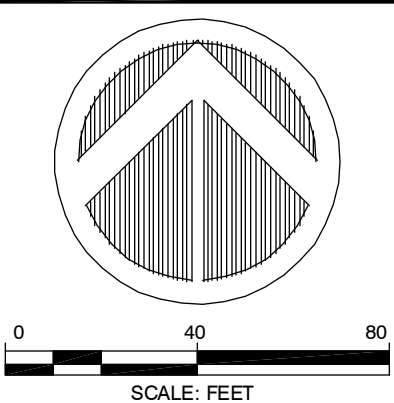

King
 ENGINEERING ASSOCIATES, INC.
 4921 Memorial Highway, One Memorial Center, Suite 300
 Tampa, Florida 33634
 Phone: (813) 880-8881, Fax: (813) 880-8882
 www.kingengineering.com
 Engineering License #2510

NO.	DATE	BY	REVISION

AMBLESIDE BLVD EXTENSION, AMENITY CENTER, AND MASS GRADING OF SOUTH FORK TRACT Q
 EISENHOWER PROPERTY GROUP LLC
 HILLSBOROUGH COUNTY
AMBLESIDE BLVD SIGNING, PAVEMENT MARKING & DIMENSION PLAN

TUYEN L. TRAN
 JAN 16, 2017
 FL P.E. No. 54099

JOB NO: 4802-502-005
 DATE: 01/16/2017
 SCALE: AS SHOWN

C3.02

PROGRESS PRINT
 01/16/2017

South Fork III Community Development District

Financial Statements
(Unaudited)

Period Ending
January 31, 2023

Prepared by:



2005 Pan Am Circle ~ Suite 300 ~ Tampa, Florida 33607
Phone (813) 873-7300 ~ Fax (813) 873-7070

SOUTH FORK III COMMUNITY DEVELOPMENT DISTRICT

Balance Sheet

As of January 31, 2023

(In Whole Numbers)

ACCOUNT DESCRIPTION	GENERAL FUND	SERIES 2016	SERIES 2018	SERIES 2019	SERIES 2016	SERIES 2018	SERIES 2019	GENERAL	GENERAL	TOTAL
		DEBT SERVICE FUND	DEBT SERVICE FUND	DEBT SERVICE FUND	CAPITAL PROJECTS FUND	CAPITAL PROJECTS FUND	CAPITAL PROJECTS FUND	FIXED ASSETS FUND	LONG-TERM DEBT FUND	
ASSETS										
Cash - Operating Account	\$ 897,548	\$ -	\$ -	\$ -	\$ -	\$ -	\$ -	\$ -	\$ -	\$ 897,548
Cash in Transit	-	16,710	2,481	30,125	-	-	-	-	-	49,316
Due From Other Funds	-	5,150	6,994	15,069	-	-	-	-	-	27,213
Investments:										
Default - Assets	-	-	-	-	-	6	-	-	-	6
Acquisition & Construction Account	-	-	-	-	-	-	3	-	-	3
Construction Fund	-	-	-	-	-	-	26	-	-	26
Deferred Cost	-	-	-	-	3	-	-	-	-	3
Prepayment Account	-	516	-	-	-	-	-	-	-	516
Reserve Fund	-	296,984	377,666	229,209	-	-	-	-	-	903,859
Revenue Fund	-	614,430	115,983	1,060,490	-	-	-	-	-	1,790,903
Fixed Assets										
Construction Work In Process	-	-	-	-	-	-	-	24,050,988	-	24,050,988
Amount Avail In Debt Services	-	-	-	-	-	-	-	-	1,650,060	1,650,060
Amount To Be Provided	-	-	-	-	-	-	-	-	23,914,940	23,914,940
TOTAL ASSETS	\$ 897,548	\$ 933,790	\$ 503,124	\$ 1,334,893	\$ 3	\$ 6	\$ 29	\$ 24,050,988	\$ 25,565,000	\$ 53,285,381
LIABILITIES										
Accounts Payable	\$ 417,206	\$ -	\$ -	\$ -	\$ -	\$ -	\$ -	\$ -	\$ -	\$ 417,206
Due To Developer	(3,698)	-	-	-	-	-	-	-	-	(3,698)
Bonds Payable	-	-	-	-	-	-	-	-	25,565,000	25,565,000
Due To Other Funds	27,210	-	-	-	-	-	3	-	-	27,213
TOTAL LIABILITIES	440,718	-	-	-	-	-	3	-	25,565,000	26,005,721

SOUTH FORK III COMMUNITY DEVELOPMENT DISTRICT

Balance Sheet

As of January 31, 2023

(In Whole Numbers)

ACCOUNT DESCRIPTION	GENERAL FUND	SERIES 2016	SERIES 2018	SERIES 2019	SERIES 2016	SERIES 2018	SERIES 2019	GENERAL	GENERAL	TOTAL
		DEBT SERVICE	DEBT SERVICE	DEBT SERVICE	CAPITAL	CAPITAL	CAPITAL	FIXED ASSETS	LONG-TERM	
		FUND	FUND	FUND	FUND	FUND	FUND	FUND	DEBT FUND	
FUND BALANCES										
Restricted for:										
Debt Service	-	933,790	503,124	1,334,893	-	-	-	-	-	2,771,807
Capital Projects	-	-	-	-	3	6	26	-	-	35
Unassigned:	456,830	-	-	-	-	-	-	24,050,988	-	24,507,818
TOTAL FUND BALANCES	456,830	933,790	503,124	1,334,893	3	6	26	24,050,988	-	27,279,660
TOTAL LIABILITIES & FUND BALANCES	\$ 897,548	\$ 933,790	\$ 503,124	\$ 1,334,893	\$ 3	\$ 6	\$ 29	\$ 24,050,988	\$ 25,565,000	\$ 53,285,381

SOUTH FORK III COMMUNITY DEVELOPMENT DISTRICT
Statement of Revenues, Expenditures and Changes in Fund Balances
For the Period Ending January 31, 2023
General Fund (001)
(In Whole Numbers)

ACCOUNT DESCRIPTION	ANNUAL ADOPTED BUDGET	YEAR TO DATE ACTUAL	VARIANCE (\$) FAV(UNFAV)	YTD ACTUAL AS A % OF ADOPTED BUD
REVENUES				
Interest - Investments	\$ -	\$ 32	\$ 32	0.00%
Interest - Tax Collector	-	479	479	0.00%
Special Assmnts- Tax Collector	1,111,369	1,099,130	(12,239)	98.90%
Other Miscellaneous Revenues	-	50	50	0.00%
TOTAL REVENUES	1,111,369	1,099,691	(11,678)	98.95%
EXPENDITURES				
<u>Administration</u>				
Supervisor Fees	12,000	2,800	9,200	23.33%
ProfServ-Trustee Fees	13,000	2,388	10,612	18.37%
Disclosure Report	12,600	4,200	8,400	33.33%
District Counsel	12,000	7,101	4,899	59.18%
District Engineer	5,000	984	4,016	19.68%
District Manager	60,000	21,002	38,998	35.00%
Auditing Services	7,300	600	6,700	8.22%
Website Compliance	1,500	3,065	(1,565)	204.33%
Mailed Notices - Postage	-	8,593	(8,593)	0.00%
Postage, Phone, Faxes, Copies	300	49	251	16.33%
Public Officials Insurance	3,110	2,786	324	89.58%
Legal Advertising	1,500	2,259	(759)	150.60%
Misc-Taxes	-	714	(714)	0.00%
Bank Fees	100	-	100	0.00%
Website Administration	1,500	500	1,000	33.33%
Dues, Licenses, Subscriptions	250	175	75	70.00%
Total Administration	130,160	57,216	72,944	43.96%
<u>Electric Utility Services</u>				
Utility - Electric	250,000	24,106	225,894	9.64%
Total Electric Utility Services	250,000	24,106	225,894	9.64%
<u>Water Utility Services</u>				
Utility - Water	80,000	1,417	78,583	1.77%
Total Water Utility Services	80,000	1,417	78,583	1.77%
<u>Garbage/Solid Waste Services</u>				
Garbage Collection	3,000	918	2,082	30.60%
Total Garbage/Solid Waste Services	3,000	918	2,082	30.60%

SOUTH FORK III COMMUNITY DEVELOPMENT DISTRICT
Statement of Revenues, Expenditures and Changes in Fund Balances
For the Period Ending January 31, 2023
General Fund (001)
(In Whole Numbers)

ACCOUNT DESCRIPTION	ANNUAL ADOPTED BUDGET	YEAR TO DATE ACTUAL	VARIANCE (\$) FAV(UNFAV)	YTD ACTUAL AS A % OF ADOPTED BUD
<u>Other Physical Environment</u>				
Waterway Management	33,140	15,440	17,700	46.59%
Clubhouse - Facility Janitorial Service	30,000	529	29,471	1.76%
Midge Fly Treatment	5,000	-	5,000	0.00%
Contracts-Janitorial Services	9,100	-	9,100	0.00%
Contracts-Pools	15,900	6,200	9,700	38.99%
Clubhouse Security Systems	10,800	1,920	8,880	17.78%
Onsite Staff	73,000	22,333	50,667	30.59%
Waterway Fish Stocking	6,000	-	6,000	0.00%
Insurance -Property & Casualty	25,000	27,162	(2,162)	108.65%
R&M-Other Landscape	10,000	-	10,000	0.00%
R&M-Mulch	47,355	-	47,355	0.00%
R&M-Pools	7,000	-	7,000	0.00%
Landscape Maint. - Seasonal Color Program	12,375	-	12,375	0.00%
Waterway Improvements & Repairs	11,000	-	11,000	0.00%
Landscape Maintenance	231,539	57,885	173,654	25.00%
Entry/Gate/Walls Maintenance	20,000	1,461	18,539	7.31%
Plant Replacement Program	15,000	31,821	(16,821)	212.14%
Irrigation Maintenance	15,000	4,537	10,463	30.25%
Holiday Lighting & Decorations	10,000	-	10,000	0.00%
Op Supplies - Clubhouse	1,000	154	846	15.40%
Total Other Physical Environment	588,209	169,442	418,767	28.81%
<u>Reserves</u>				
Capital Improvements	30,000	-	30,000	0.00%
Capital Reserve	30,000	-	30,000	0.00%
Total Reserves	60,000	-	60,000	0.00%
TOTAL EXPENDITURES & RESERVES	1,111,369	253,099	858,270	22.77%
Excess (deficiency) of revenues				
Over (under) expenditures	-	846,592	846,592	0.00%
FUND BALANCE, BEGINNING (OCT 1, 2022)		(389,762)		
FUND BALANCE, ENDING		\$ 456,830		

SOUTH FORK III COMMUNITY DEVELOPMENT DISTRICT
Statement of Revenues, Expenditures and Changes in Fund Balances
For the Period Ending January 31, 2023
Series 2016 Debt Service Fund (200)
(In Whole Numbers)

ACCOUNT DESCRIPTION	ANNUAL ADOPTED BUDGET	YEAR TO DATE ACTUAL	VARIANCE (\$) FAV(UNFAV)	YTD ACTUAL AS A % OF ADOPTED BUD
REVENUES				
Interest - Investments	\$ -	\$ 7	\$ 7	0.00%
Interest - Tax Collector	-	264	264	0.00%
Special Assmnts- Tax Collector	595,400	606,372	10,972	101.84%
TOTAL REVENUES	595,400	606,643	11,243	101.89%
EXPENDITURES				
<u>Debt Service</u>				
Principal Debt Retirement	160,000	-	160,000	0.00%
Principal Prepayments	-	5,000	(5,000)	0.00%
Interest Expense	435,400	218,897	216,503	50.27%
Total Debt Service	595,400	223,897	371,503	37.60%
TOTAL EXPENDITURES	595,400	223,897	371,503	37.60%
Excess (deficiency) of revenues Over (under) expenditures	-	382,746	382,746	0.00%
FUND BALANCE, BEGINNING (OCT 1, 2022)		551,044		
FUND BALANCE, ENDING		\$ 933,790		

SOUTH FORK III COMMUNITY DEVELOPMENT DISTRICT
Statement of Revenues, Expenditures and Changes in Fund Balances
For the Period Ending January 31, 2023
Series 2018 Debt Service Fund (202)
(In Whole Numbers)

ACCOUNT DESCRIPTION	ANNUAL ADOPTED BUDGET	YEAR TO DATE ACTUAL	VARIANCE (\$) FAV(UNFAV)	YTD ACTUAL AS A % OF ADOPTED BUD
REVENUES				
Interest - Investments	\$ -	\$ 9	\$ 9	0.00%
Interest - Tax Collector	-	39	39	0.00%
Special Assmnts- Tax Collector	754,212	95,371	(658,841)	12.65%
TOTAL REVENUES	754,212	95,419	(658,793)	12.65%
EXPENDITURES				
<u>Debt Service</u>				
Principal Debt Retirement	200,000	-	200,000	0.00%
Interest Expense	554,212	279,106	275,106	50.36%
Total Debt Service	754,212	279,106	475,106	37.01%
TOTAL EXPENDITURES	754,212	279,106	475,106	37.01%
Excess (deficiency) of revenues				
Over (under) expenditures	-	(183,687)	(183,687)	0.00%
FUND BALANCE, BEGINNING (OCT 1, 2022)		686,811		
FUND BALANCE, ENDING		\$ 503,124		

SOUTH FORK III COMMUNITY DEVELOPMENT DISTRICT
Statement of Revenues, Expenditures and Changes in Fund Balances
For the Period Ending January 31, 2023
Series 2019 Debt Service Fund (203)
(In Whole Numbers)

ACCOUNT DESCRIPTION	ANNUAL ADOPTED BUDGET	YEAR TO DATE ACTUAL	VARIANCE (\$) FAV(UNFAV)	YTD ACTUAL AS A % OF ADOPTED BUD
REVENUES				
Interest - Investments	\$ -	\$ 6	\$ 6	0.00%
Interest - Tax Collector	-	475	475	0.00%
Special Assmnts- Tax Collector	453,850	1,088,033	634,183	239.73%
TOTAL REVENUES	453,850	1,088,514	634,664	239.84%
EXPENDITURES				
Debt Service				
Principal Debt Retirement	120,000	115,000	5,000	95.83%
Interest Expense	333,850	169,238	164,612	50.69%
Total Debt Service	453,850	284,238	169,612	62.63%
TOTAL EXPENDITURES	453,850	284,238	169,612	62.63%
Excess (deficiency) of revenues				
Over (under) expenditures	-	804,276	804,276	0.00%
OTHER FINANCING SOURCES (USES)				
Operating Transfers-Out	-	(1)	(1)	0.00%
TOTAL FINANCING SOURCES (USES)	-	(1)	(1)	0.00%
Net change in fund balance	\$ -	\$ 804,275	\$ 804,275	0.00%
FUND BALANCE, BEGINNING (OCT 1, 2022)		530,617		
FUND BALANCE, ENDING		\$ 1,334,892		

SOUTH FORK III COMMUNITY DEVELOPMENT DISTRICT
Statement of Revenues, Expenditures and Changes in Fund Balances
For the Period Ending January 31, 2023
Series 2016 Capital Projects Fund (300)
(In Whole Numbers)

ACCOUNT DESCRIPTION	ANNUAL ADOPTED BUDGET	YEAR TO DATE ACTUAL	VARIANCE (\$) FAV(UNFAV)	YTD ACTUAL AS A % OF ADOPTED BUD
REVENUES				
TOTAL REVENUES	-	-	-	0.00%
EXPENDITURES				
TOTAL EXPENDITURES	-	-	-	0.00%
Excess (deficiency) of revenues				
Over (under) expenditures	-	-	-	0.00%
FUND BALANCE, BEGINNING (OCT 1, 2022)		3		
FUND BALANCE, ENDING		\$ 3		

SOUTH FORK III COMMUNITY DEVELOPMENT DISTRICT
Statement of Revenues, Expenditures and Changes in Fund Balances
For the Period Ending January 31, 2023
Series 2018 Capital Projects Fund (302)
(In Whole Numbers)

ACCOUNT DESCRIPTION	ANNUAL ADOPTED BUDGET	YEAR TO DATE ACTUAL	VARIANCE (\$) FAV(UNFAV)	YTD ACTUAL AS A % OF ADOPTED BUD
REVENUES				
TOTAL REVENUES	-	-	-	0.00%
EXPENDITURES				
TOTAL EXPENDITURES	-	-	-	0.00%
Excess (deficiency) of revenues				
Over (under) expenditures	-	-	-	0.00%
FUND BALANCE, BEGINNING (OCT 1, 2022)		6		
FUND BALANCE, ENDING		\$ 6		

SOUTH FORK III COMMUNITY DEVELOPMENT DISTRICT
Statement of Revenues, Expenditures and Changes in Fund Balances
For the Period Ending January 31, 2023
Series 2019 Capital Projects Fund (303)
(In Whole Numbers)

ACCOUNT DESCRIPTION	ANNUAL ADOPTED BUDGET	YEAR TO DATE ACTUAL	VARIANCE (\$) FAV(UNFAV)	YTD ACTUAL AS A % OF ADOPTED BUD
REVENUES				
TOTAL REVENUES	-	-	-	0.00%
EXPENDITURES				
TOTAL EXPENDITURES	-	-	-	0.00%
Excess (deficiency) of revenues Over (under) expenditures	-	-	-	0.00%
OTHER FINANCING SOURCES (USES)				
Interfund Transfer - In	-	1	1	0.00%
TOTAL FINANCING SOURCES (USES)	-	1	1	0.00%
Net change in fund balance	\$ -	\$ 1	\$ 1	0.00%
FUND BALANCE, BEGINNING (OCT 1, 2022)		25		
FUND BALANCE, ENDING		\$ 26		

SOUTH FORK III COMMUNITY DEVELOPMENT DISTRICT
Statement of Revenues, Expenditures and Changes in Fund Balances
For the Period Ending January 31, 2023
General Fixed Assets Fund (900)
(In Whole Numbers)

ACCOUNT DESCRIPTION	ANNUAL ADOPTED BUDGET	YEAR TO DATE ACTUAL	VARIANCE (\$) FAV(UNFAV)	YTD ACTUAL AS A % OF ADOPTED BUD
REVENUES				
TOTAL REVENUES	-	-	-	0.00%
EXPENDITURES				
TOTAL EXPENDITURES	-	-	-	0.00%
Excess (deficiency) of revenues				
Over (under) expenditures	-	-	-	0.00%
FUND BALANCE, BEGINNING (OCT 1, 2022)		24,050,988		
FUND BALANCE, ENDING		\$ 24,050,988		

SOUTH FORK III CDD

Bank Reconciliation

Bank Account No. 8694 TRUIST - GF Operating
 Statement No. 01-23
 Statement Date 1/31/2023

G/L Balance (LCY)	897,547.94	Statement Balance	898,037.91
G/L Balance	897,547.94	Outstanding Deposits	0.00
Positive Adjustments	0.00		
		Subtotal	898,037.91
Subtotal	897,547.94	Outstanding Checks	489.97
Negative Adjustments	0.00	Differences	0.00
Ending G/L Balance	897,547.94	Ending Balance	897,547.94
Difference	0.00		

Posting Date	Document Type	Document No.	Description	Amount	Cleared Amount	Difference
Checks						
12/6/2022	Payment	2538	ZEBRA CLEANING TEAM	2,950.00	2,950.00	0.00
12/7/2022	Payment	2544	RYAN MOTKO	200.00	200.00	0.00
12/13/2022	Payment	2549	SOUTH FORK III CDD	1,548,727.56	1,548,727.56	0.00
12/21/2022	Payment	2553	STRALEY ROBIN VERICKER	3,379.27	3,379.27	0.00
12/23/2022	Payment	2555	SOUTH FORK III CDD	63,683.55	63,683.55	0.00
12/28/2022	Payment	2557	BAY AREA PUMP AND WELL SERVICE LLC	2,899.00	2,899.00	0.00
12/28/2022	Payment	2558	CHARTER COMMUNICATIONS	94.97	94.97	0.00
12/28/2022	Payment	2559	INNERSYNC STUDIO, Ltd	3,064.80	3,064.80	0.00
12/28/2022	Payment	2560	LANDSCAPE MAINTENANCE	12,438.81	12,438.81	0.00
12/28/2022	Payment	2561	WJ WORLDWIDE PROTECTION SERV	4,425.00	4,425.00	0.00
1/6/2023	Payment	2562	LANDSCAPE MAINTENANCE	57,883.40	57,883.40	0.00
1/6/2023	Payment	2563	SOUTH FORK III CDD	13,390.98	13,390.98	0.00
1/6/2023	Payment	2565	TAMPA ELECTRIC	5,729.58	5,729.58	0.00
1/6/2023	Payment	2566	WASTE MANAGEMENT INC OF FLORIDA	232.22	232.22	0.00
1/12/2023	Payment	2567	BOCC	530.32	530.32	0.00
1/12/2023	Payment	2568	CHARTER COMMUNICATIONS	242.96	242.96	0.00
1/12/2023	Payment	2569	DARRYL F. DEW	200.00	200.00	0.00
1/12/2023	Payment	2570	FIRST CHOICE AQUATIC	2,470.00	2,470.00	0.00
1/12/2023	Payment	2571	INFRAMARK LLC	23,720.46	23,720.46	0.00
1/12/2023	Payment	2572	LANDSCAPE MAINTENANCE	12,625.44	12,625.44	0.00
1/12/2023	Payment	2574	STRALEY ROBIN VERICKER	976.00	976.00	0.00
1/12/2023	Payment	2575	SUSAN PELTZ	200.00	200.00	0.00
Total Checks				1,760,064.32	1,760,064.32	0.00
Deposits						
1/5/2023		JE000070	Debt Service/Tax Revenue	G/L 79,683.90	79,683.90	0.00
1/23/2023		JE000088	HLLS TAX INTEREST	G/L 1,256.59	1,256.59	0.00
1/31/2023		JE000071	Interest - payment	G/L 9.73	9.73	0.00
Total Deposits				80,950.22	80,950.22	0.00

SOUTH FORK III CDD

Bank Reconciliation

Posting Date	Document Type	Document No.	Description	Amount	Cleared Amount	Difference
Outstanding Checks						
11/16/2022	Payment	2517	RYAN MOTKO	200.00	0.00	200.00
1/12/2023	Payment	2573	SCOTT D. CORDER	200.00	0.00	200.00
1/27/2023	Payment	2576	SPECTRUM	89.97	0.00	89.97
Total Outstanding Checks.....				489.97		489.97

South Fork III Community Development District

**Score Sheet for Request for Proposals for
Landscaping Maintenance Services**

SUPERVISOR Darryl F. Dew

Please fill in the numbers for each category for all proposers.

Candidates	BrightView	Pine Lake	South County	LMP	Red Tree	Field Stone
Personnel (25 points)	12.5	12.5	12.5	12.5	12.5	12.5
Experience (30 Points) (Possible Additional 5 Points)	20	18	22	20	22	15
Understanding Scope of RFP (15 Points)	10.5	10.5	10.5	10.5	10.5	10.5
Price (20 Points)	15	17	17	15	∅	∅
Reasonableness of ALL Numbers (5 Points)	2	3	3	3	2	2
Total score for each candidate	60	61	65	61	48	40

South Fork III Community Development District

**Score Sheet for Request for Proposals for
Landscaping Maintenance Services**

SUPERVISOR S. Cooper

Please fill in the numbers for each category for all proposers.

Candidates	Bright View	S. Cooper	CMP	River Lake	Frab Stone
Personnel (25 points)	25	20	15	20	∅
Experience (30 Points) (Possible Additional 5 Points)	25	25	25	25	∅
Understanding Scope of RFP (15 Points)	15	15	15	15	∅
Price (20 Points)	15	20	20	20	∅
Reasonableness of ALL Numbers (5 Points)	90 4	80 3	75 1	80 2	∅
Total score for each candidate	94	83	76	82	∅

South Fork III Community Development District

**Score Sheet for Request for Proposals for
Landscaping Maintenance Services**

SUPERVISOR SUSAN PELTZ

Please fill in the numbers for each category for all proposers.

Candidates	PINE LAKE	SOUTH COUNTY	LMP	RED TREE	BRIGHT VIEW	FIELD STONE
Personnel (25 points)	15	20	10	15	20	15
Experience (30 Points) (Possible Additional 5 Points)	20	28	25	20	28	20
Understanding Scope of RFP (15 Points)	10	15	10	10	15	10
Price (20 Points)	20	19	15	0	18	0
Reasonableness of ALL Numbers (5 Points)	3	5	0	0	4	0
Total score for each candidate	68	87	40	45	85	45